

Embedded data collector (EDC) Evaluation phase II – Comparison with instrumented Static Load Tests

FDOT Contract No.: BDK-75-977-24

Project Managers:

Rodrigo Herrera, PE

Peter Lai, PE

Principal Investigator:

Mike McVay, PhD

David Bloomquist, PhD, PE

Primary Researchers:

Khiem Tran, PhD

Krishnaro Dase, M.S.



Overview

- TASK 1 : EDC – PDA – CAPWAP Comparison
 - Capacities, Stresses, Energies, and Beta
- Task 2: Database – Measured Static Resistance vs. Estimated Resistance from Dynamic Measurements
- Task 3: Pile Freeze – Prediction of Pile Skin Friction and End Bearing separately and changes in each with time

TASK 1 : EDC – PDA Comparison

139 Monitored Piles and 213,000 Blows

tal
ng

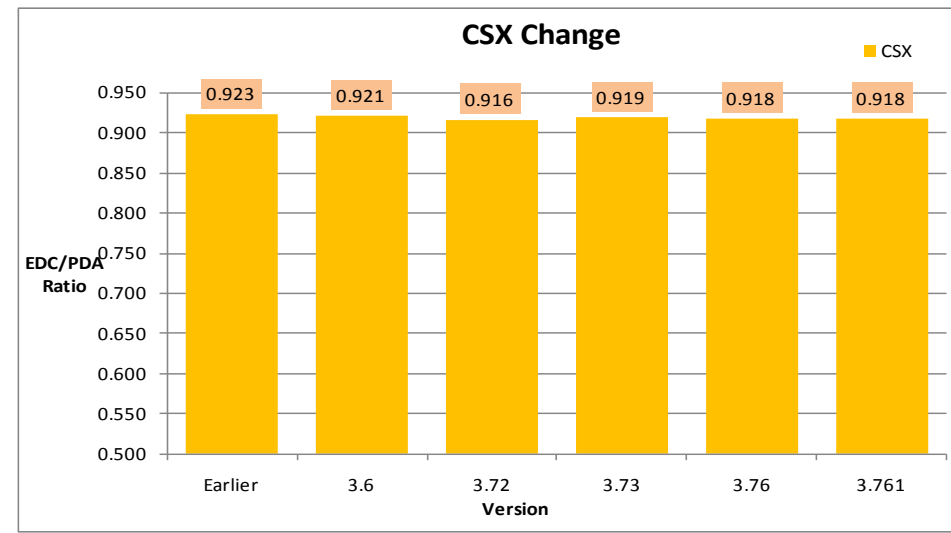
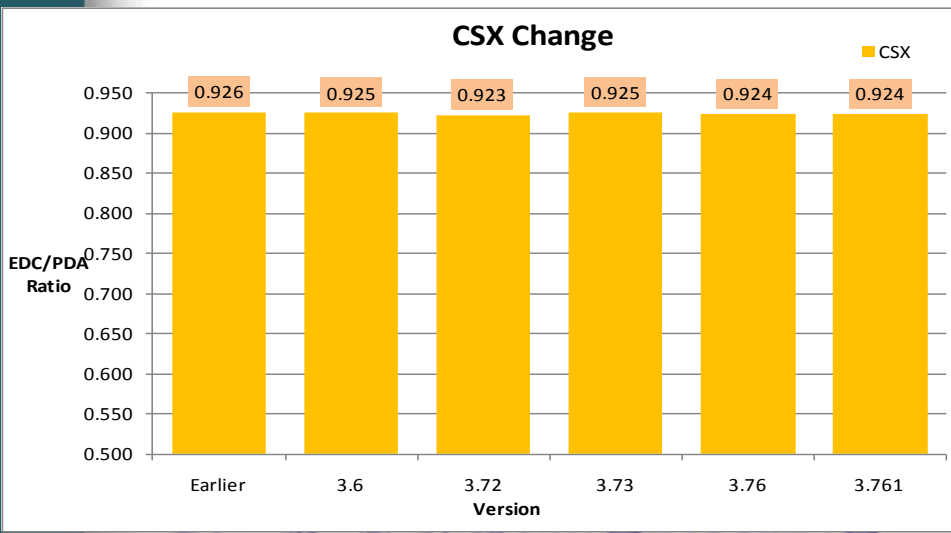
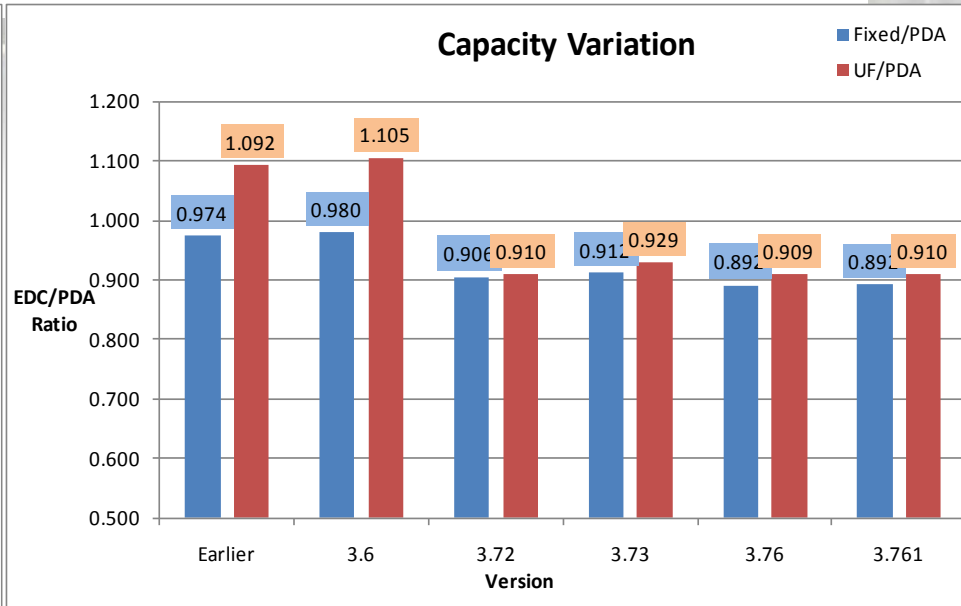
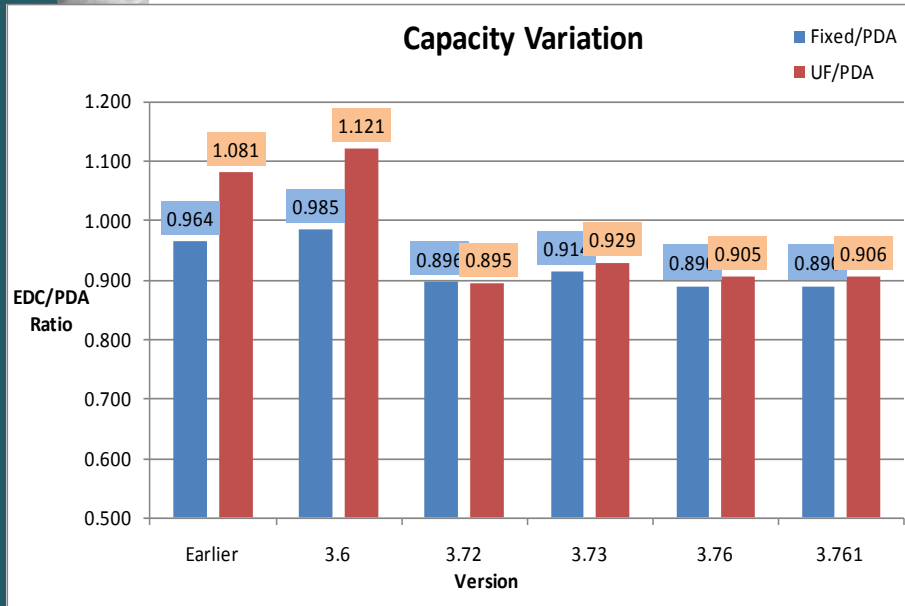

TASK 1 : EDC – PDA Comparison

139 Monitored Piles and 213,000 Blows

stal
ing

CSB Change

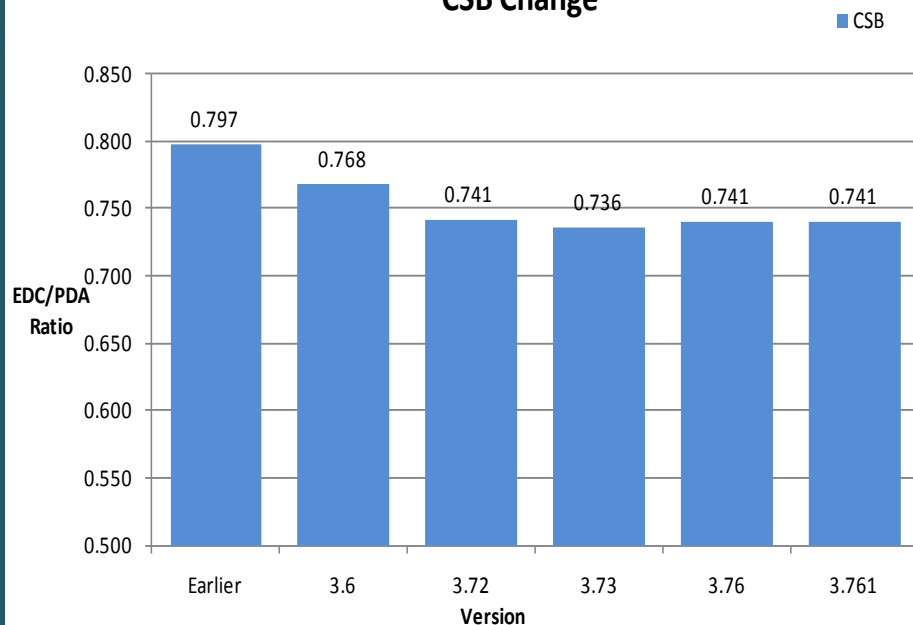

CSB Change

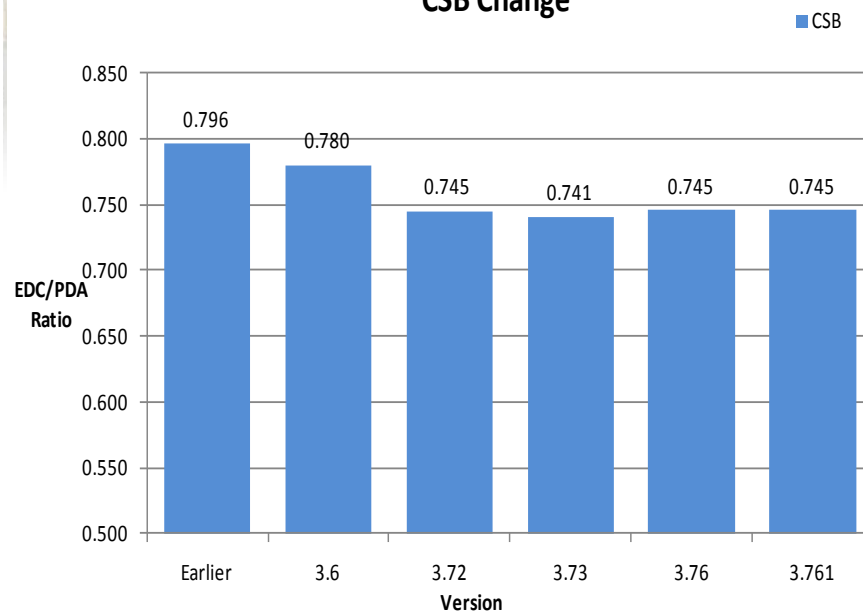

TSX Change

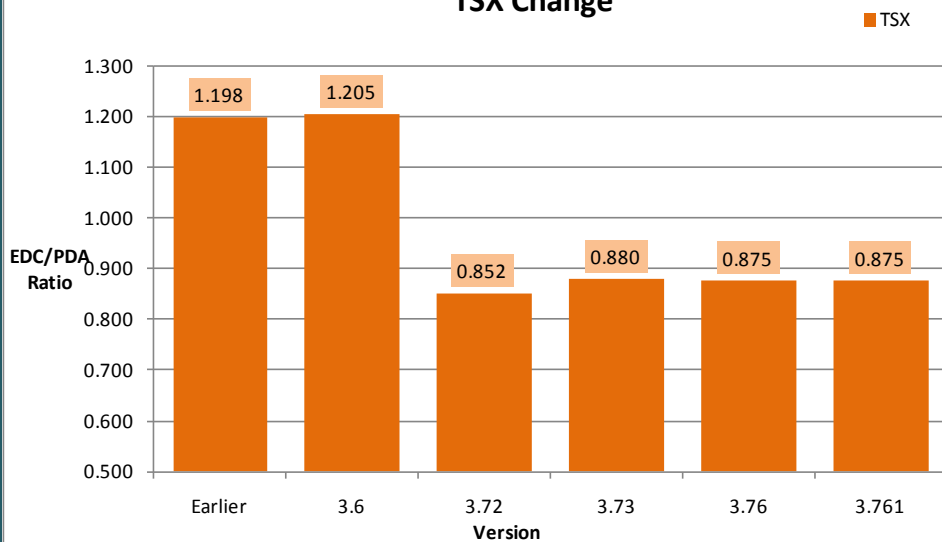

TSX Change

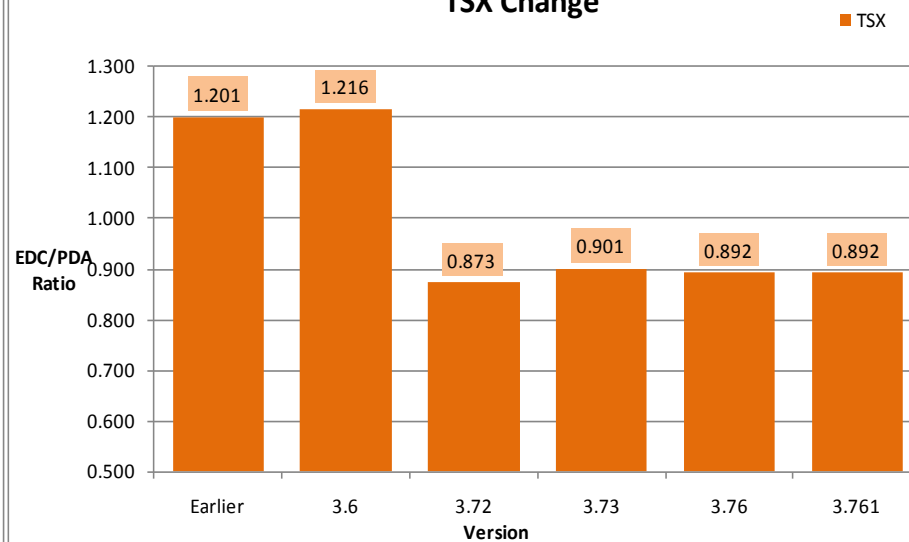

TASK 1 : EDC – PDA Comparison 139 Monitored Piles and 213,000 Blows

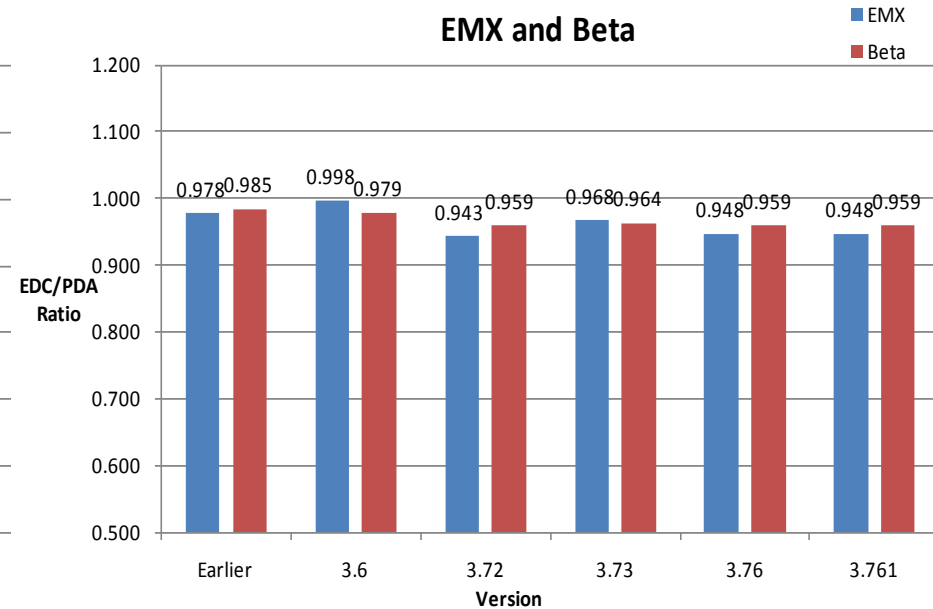
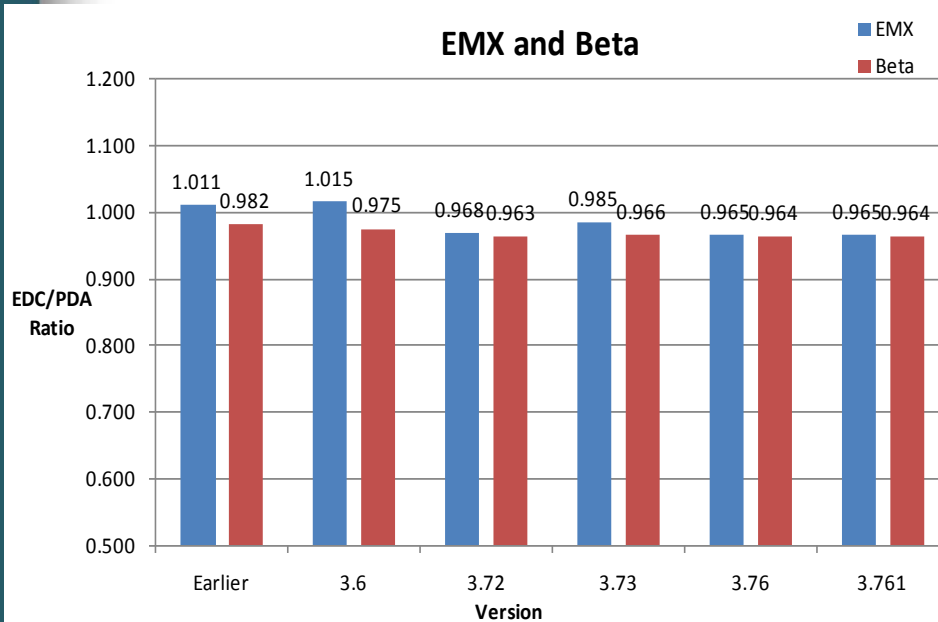

EDC vs. CAPWAP, Early Version -3.6

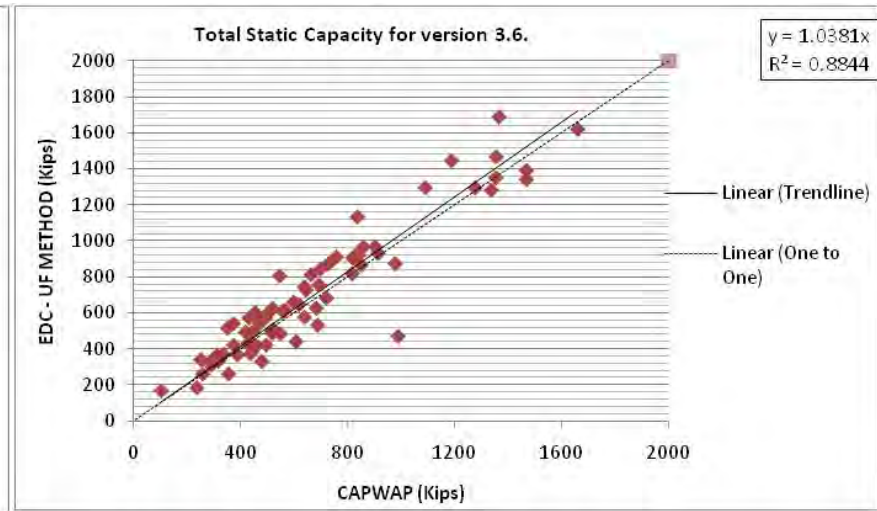
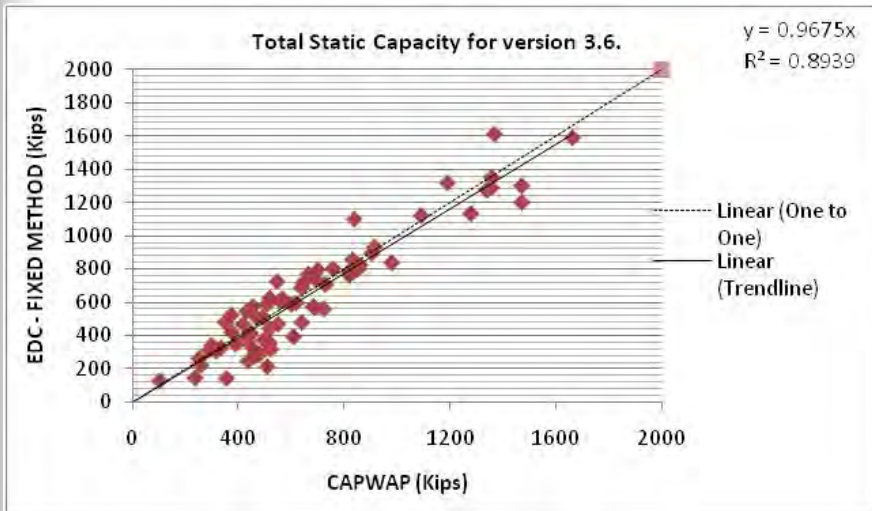
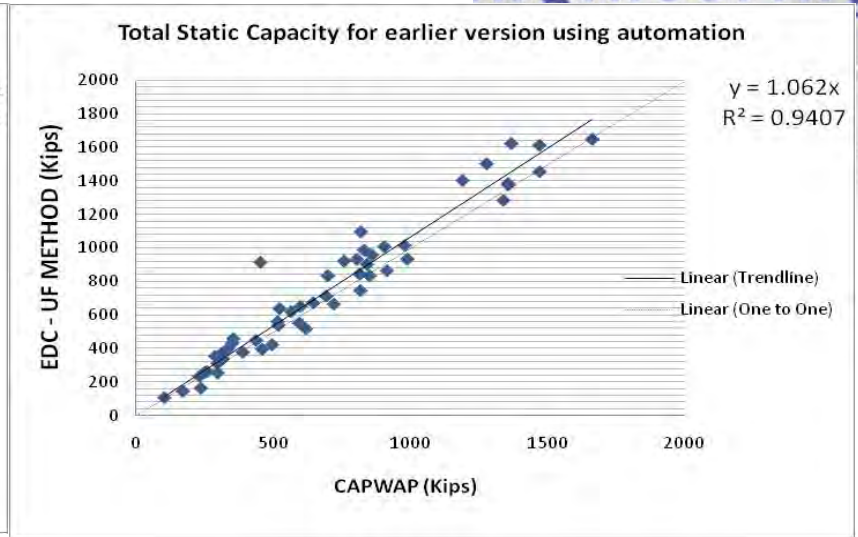
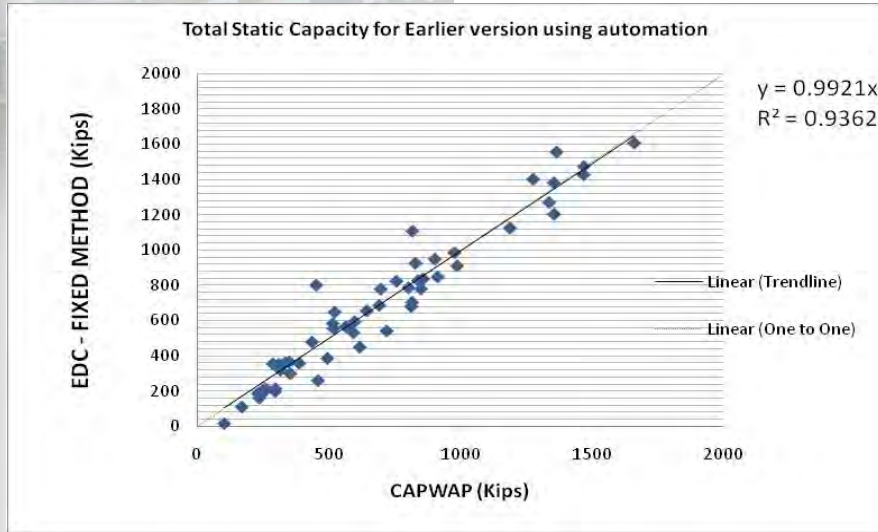

EDC Version 3.72 – CAPWAP Comparison

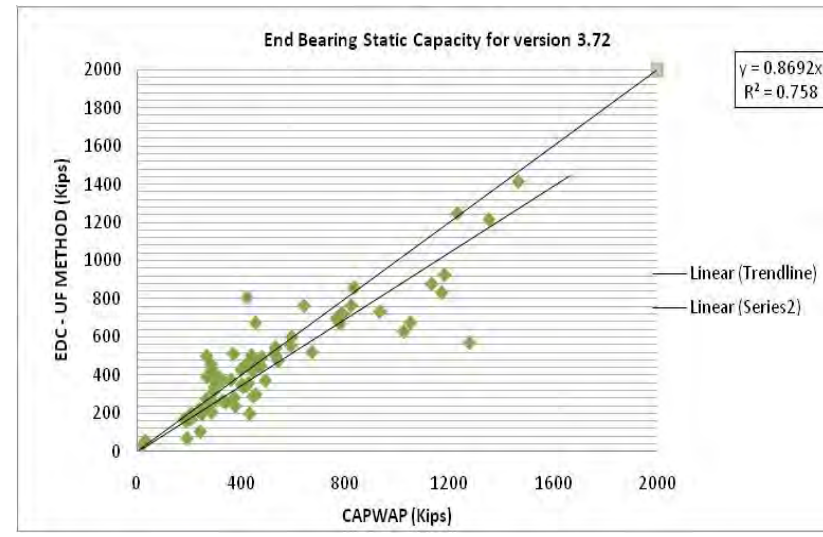
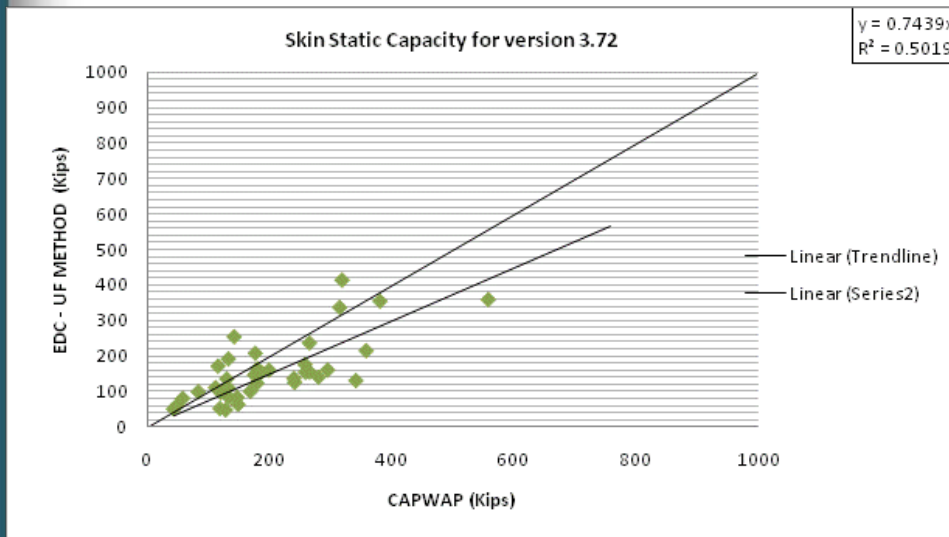
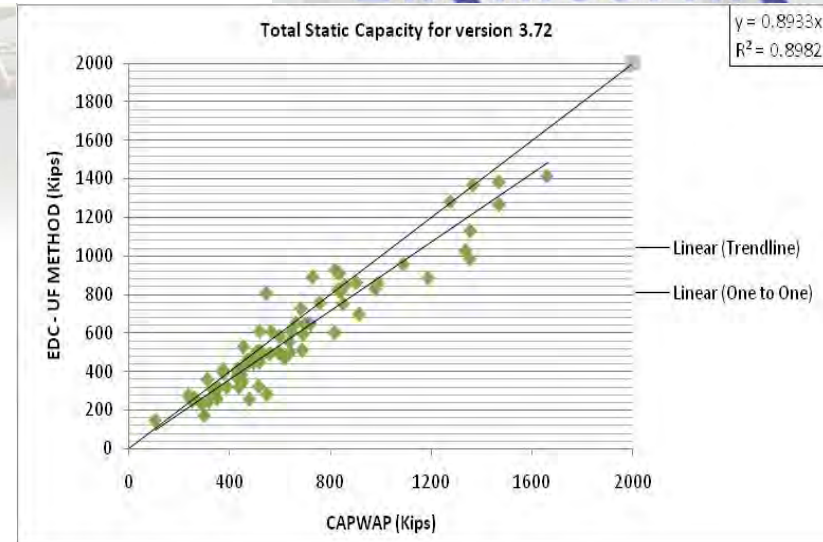
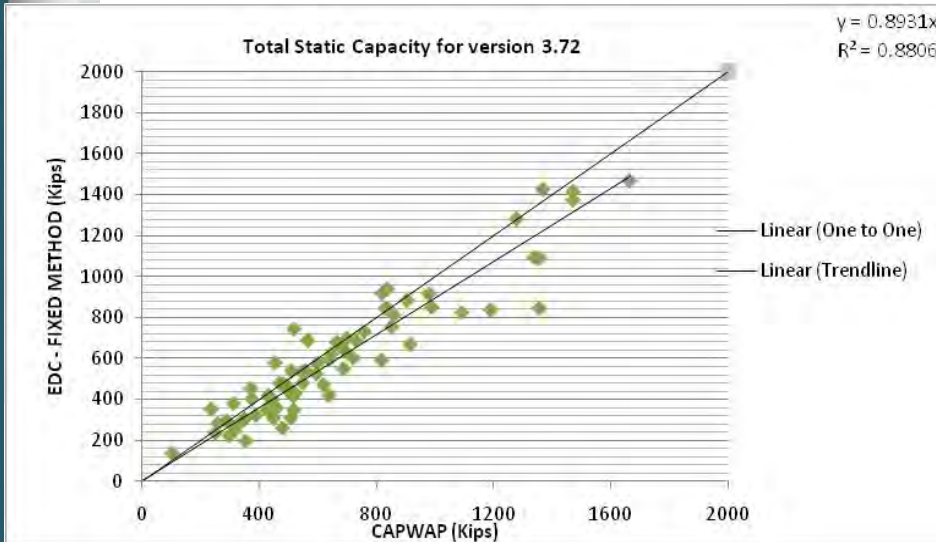

EDC Version 3.73 – CAPWAP Comparison

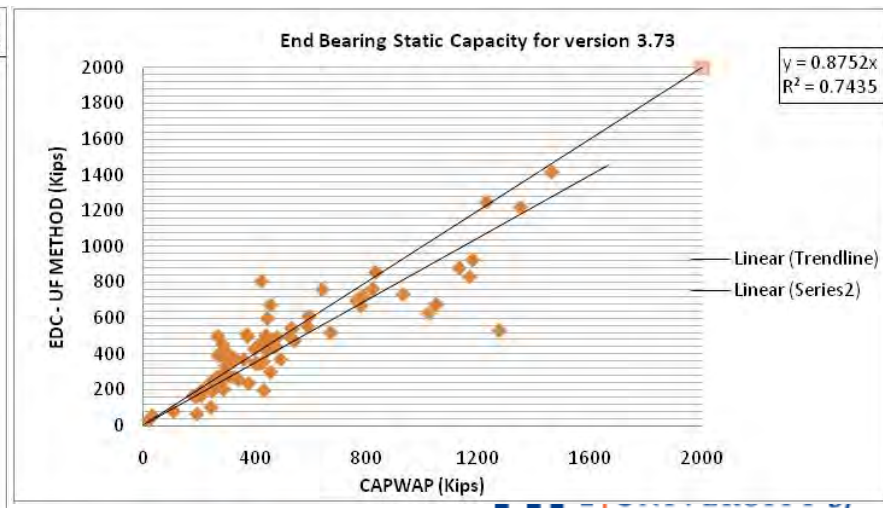
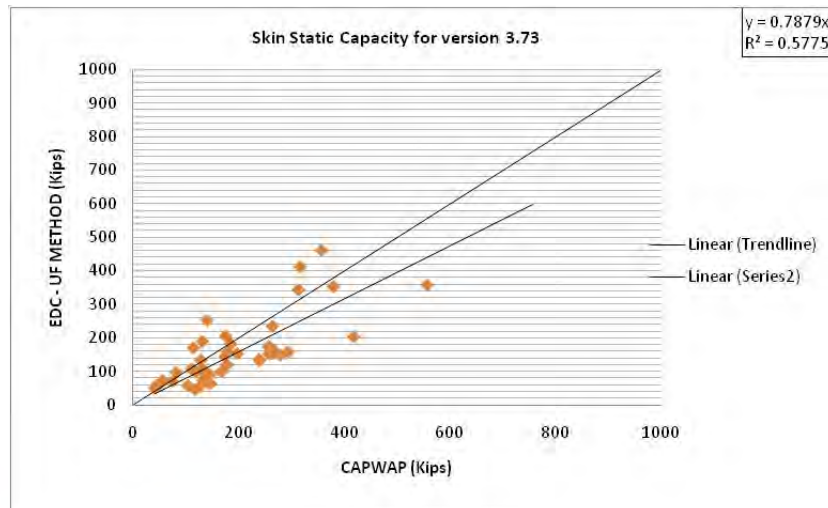
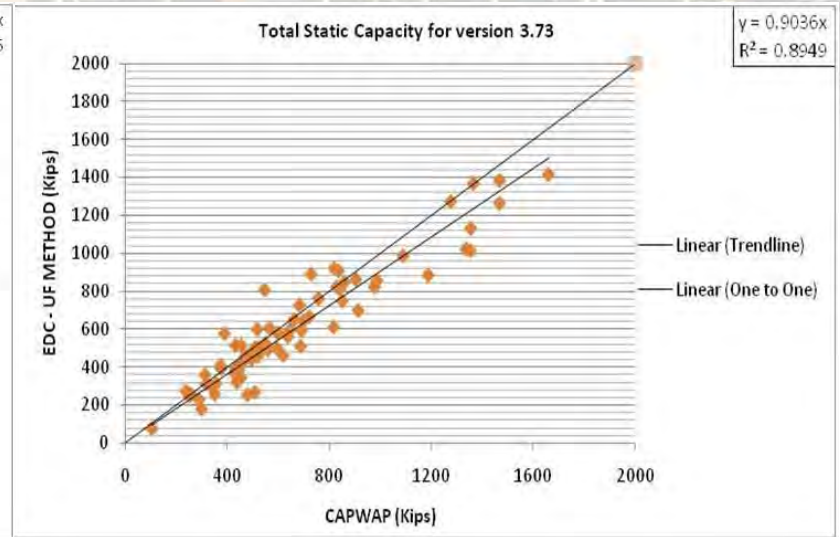
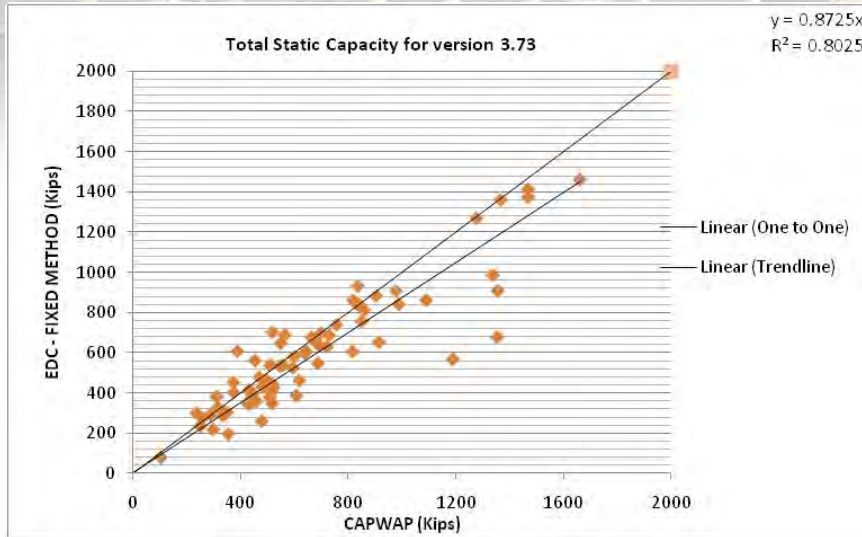

EDC Version 3.761 – CAPWAP Comparison

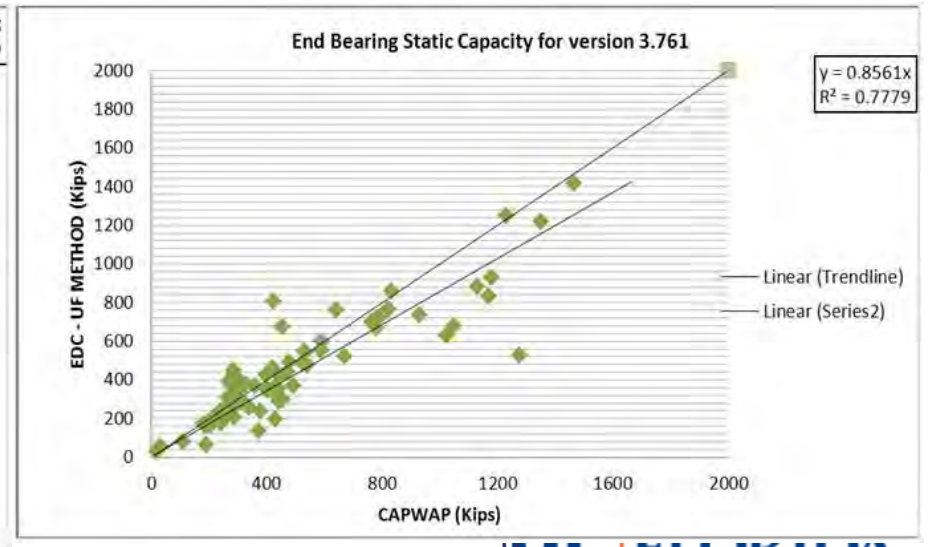
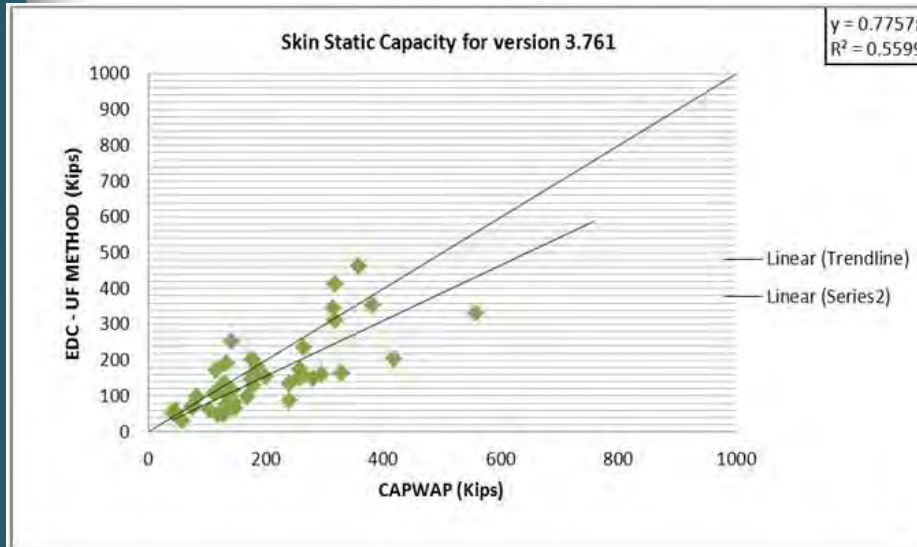
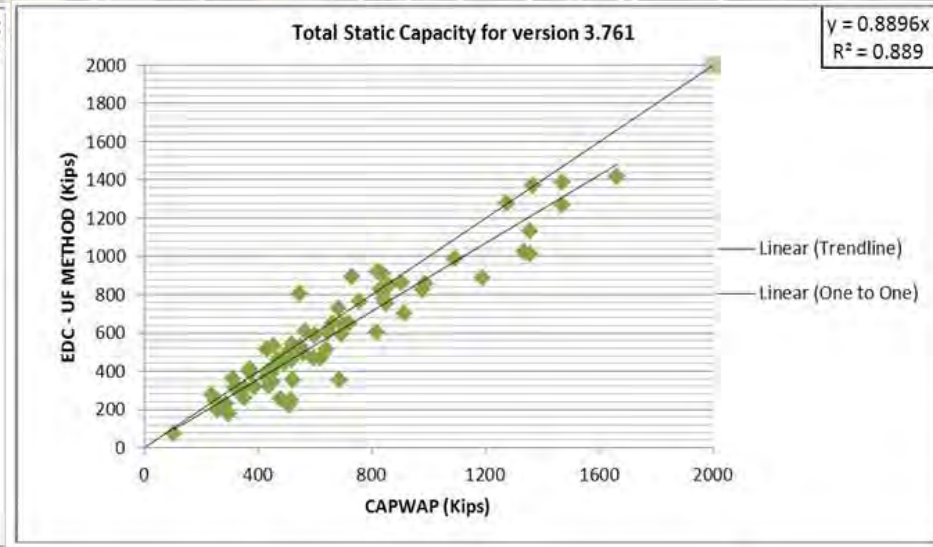
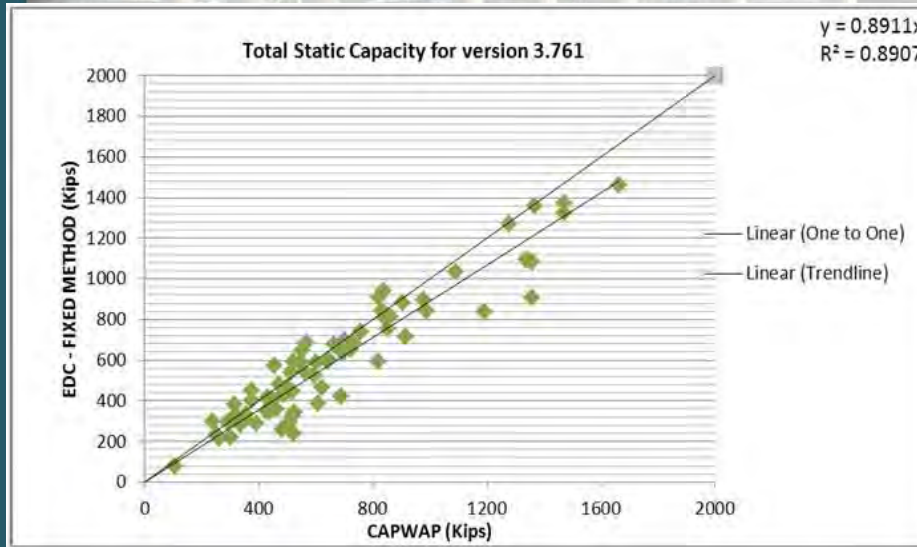

Statistical Results for various versions

SMART PILE VERSION - 3.72

Based on per pile, Smart Pile version 3.72							
	Fixed/PDA	UF/PDA	CSX	CSB	TSX	EMX	Beta
Count	137	138	137	132	130	136	132
Average	0.89605	0.89489	0.92279	0.74142	0.85162	0.96803	0.96344
Stddev	0.14900	0.17115	0.09154	0.17697	0.26635	0.25627	0.10483
COV	0.16629	0.19126	0.09920	0.23869	0.31276	0.26473	0.10880
%n	0.98561	0.98571	0.98561	0.95652	0.98485	0.98551	0.96350
Median	0.92753	0.91182	0.93055	0.74932	0.89364	0.93301	0.99598

Based on Concurrent blows, Smart Pile version version 3.72							
	Fixed/PDA	UF/PDA	CSX	CSB	TSX	EMX	Beta
Count	137	138	137	132	130	136	132
#Blows	212463	212904	209253	204094	205828	212123	204497
Sum	192408.9	193703.4	191708.1	152097.6	179718.2	200074.4	196167.8
Average	0.90561	0.90982	0.91615	0.74523	0.87315	0.94320	0.95927
Stddev	0.14900	0.17115	0.09154	0.17697	0.26635	0.25627	0.10483
COV	0.16453	0.18812	0.09992	0.23747	0.30505	0.27170	0.10928
%n	0.88155	0.88748	0.87834	0.69685	0.82340	0.91667	0.89877
Median	0.92753	0.91182	0.93055	0.74932	0.89364	0.93301	0.99598

SMART PILE VERSION - 3.6

Based on per pile, Smart Pile version 3.6							
	Fixed/PDA	UF/PDA	CSX	CSB	TSX	EMX	Beta
Count	137	138	137	132	131	136	134
Average	0.98460	1.12123	0.92490	0.76775	1.20457	1.01528	0.97500
Stddev	0.17387	0.24122	0.08891	0.17862	0.29364	0.22608	0.04292
COV	0.17659	0.21514	0.09613	0.23266	0.24377	0.22268	0.04402
%n	0.97857	0.98571	0.98561	0.97059	0.98496	0.98551	0.97810
Median	0.98718	1.10558	0.92482	0.77918	1.20217	1.00839	0.97353

Based on Concurrent blows, Smart Pile version version 3.6							
	Fixed/PDA	UF/PDA	CSX	CSB	TSX	EMX	Beta
Count	137	138	137	132	131	136	134
#Blows	212014	212865	209253	204498	205119	210158	207098
Sum	207787.0	235262.9	192798.4	159467.6	249399.4	209675.1	202700.6
Average	0.98006	1.10522	0.92137	0.77980	1.21588	0.99770	0.97877
Stddev	0.17387	0.24122	0.08891	0.17862	0.29364	0.22608	0.04292
COV	0.17740	0.21825	0.09650	0.22906	0.24150	0.22660	0.04386
%n	0.95200	1.07789	0.88333	0.73062	1.14266	0.96065	0.92870
Median	0.98718	1.10558	0.92482	0.77918	1.20217	1.00839	0.97353

SMART PILE (EARLIER VERSION)

Based on per pile, Earlier version of Smart Pile							
	Fixed/PDA	UF/PDA	CSX	CSB	TSX	EMX	Beta
Count	137	136	136	132	129	136	132
Average	0.96435	1.08137	0.92640	0.79733	1.19847	1.01084	0.98178
Stddev	0.18514	0.19845	0.08642	0.18672	0.28952	0.21628	0.03612
COV	0.19199	0.18352	0.09328	0.23418	0.24157	0.21396	0.03679
%n	0.98561	0.97842	0.98551	0.95652	0.97727	0.99270	0.97059
Median	0.95484	1.08013	0.93020	0.81627	1.20760	1.00194	0.97986

Based on Concurrent blows, Earlier version of Smart Pile							
	Fixed/PDA	UF/PDA	CSX	CSB	TSX	EMX	Beta
Count	137	136	136	132	129	136	132
#Blows	209683	208505	205867	201138	200582	208832	203447
Sum	204202.7	227738.7	190065.2	160121.4	240833.1	204175.1	200358.4
Average	0.97386	1.09225	0.92324	0.79608	1.20067	0.97770	0.98482
Stddev	0.18514	0.19845	0.08642	0.18672	0.28952	0.21628	0.03612
COV	0.19011	0.18169	0.09360	0.23455	0.24113	0.22121	0.03668
%n	0.93558	1.04341	0.87081	0.73362	1.10341	0.93545	0.91797
Median	0.95484	1.08013	0.93020	0.81627	1.20760	1.00194	0.97986

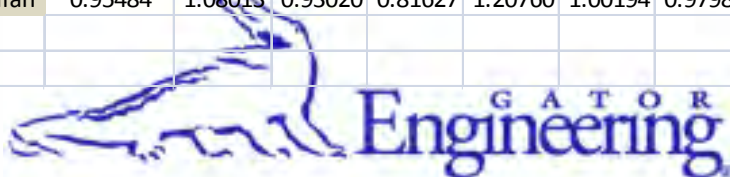

Statistical Results for various versions : Based on Per Pile

SMART PILE VERSION - 3.761 (all piles, old + new) - 7/27/2011

Based on per pile, Smart Pile version 3.761							
	Fixed/PDA	UF/PDA	CSX	CSB	TSX	EMX	Beta
Count	148	148	149	143	140	148	147
Average	0.89277	0.90959	0.93195	0.74471	0.87614	0.98772	0.96620
Stddev	0.14992	0.15786	0.09558	0.17598	0.25159	0.25370	0.10824
COV	0.16792	0.17354	0.10256	0.23630	0.28716	0.25685	0.11202
%n	0.98667	0.98667	0.99333	0.95973	0.98592	0.98667	0.98000
Median	0.92610	0.91317	0.93820	0.74987	0.89874	0.96670	0.99576

Based on Concurrent blows, Smart Pile version 3.761							
	Fixed/PDA	UF/PDA	CSX	CSB	TSX	EMX	Beta
Count	148	148	149	143	140	148	147
#Blows	233824	233673	233844	225455	226138	233579	230933
Sum	208926.7	213868.5	217434.3	168829.3	201612.2	227872.2	222098.5
Average	0.89352	0.91525	0.92983	0.74884	0.89155	0.97557	0.96174
Stddev	0.14992	0.15786	0.09558	0.17598	0.25159	0.25370	0.10824
COV	0.16778	0.17247	0.10279	0.23500	0.28220	0.26005	0.11254
%n	0.87710	0.89784	0.91281	0.70877	0.84639	0.95663	0.93240
Median	0.92610	0.91317	0.93820	0.74987	0.89874	0.96670	0.99576

SMART PILE VERSION - 3.76

Based on per pile, Smart Pile version 3.76							
	Fixed/PDA	UF/PDA	CSX	CSB	TSX	EMX	Beta
Count	139	139	140	134	131	138	139
Average	0.88997	0.90531	0.92404	0.74054	0.87543	0.96528	0.96369
Stddev	0.15203	0.16045	0.09198	0.17708	0.25881	0.24182	0.11700
COV	0.17082	0.17724	0.09954	0.23912	0.29564	0.25052	0.12140
%n	0.98582	0.98582	0.99291	0.95714	0.98496	0.97872	0.98582
Median	0.92586	0.91074	0.93168	0.74932	0.90079	0.93429	0.99587

Based on Concurrent blows, Smart Pile version 3.76							
	Fixed/PDA	UF/PDA	CSX	CSB	TSX	EMX	Beta
Count	139	139	140	134	131	138	139
#Blows	213885	213734	213905	205516	206199	213157	213631
Sum	190710.6	194347.2	196359.3	153196.6	183988.1	201986.4	204897.3
Average	0.89165	0.90929	0.91797	0.74542	0.89228	0.94759	0.95912
Stddev	0.15203	0.16045	0.09198	0.17708	0.25881	0.24182	0.11700
COV	0.17050	0.17646	0.10020	0.23755	0.29006	0.25519	0.12198
%n	0.87377	0.89043	0.89965	0.70189	0.84297	0.92543	0.93876
Median	0.92586	0.91074	0.93168	0.74932	0.90079	0.93429	0.99587

SMART PILE VERSION - 3.73

Based on per pile, Smart Pile version 3.73							
	Fixed/PDA	UF/PDA	CSX	CSB	TSX	EMX	Beta
Count	138	139	140	135	131	138	138
Average	0.91352	0.92878	0.92511	0.73569	0.88048	0.98537	0.96576
Stddev	0.15199	0.18849	0.09310	0.18510	0.27464	0.24012	0.11164
COV	0.16637	0.20295	0.10064	0.25159	0.31192	0.24369	0.11560
%n	0.97872	0.98582	0.99291	0.96429	0.98496	0.97872	0.97872
Median	0.93089	0.92671	0.93319	0.74539	0.89883	0.96686	0.99600

Based on Concurrent blows, Smart Pile version 3.73							
	Fixed/PDA	UF/PDA	CSX	CSB	TSX	EMX	Beta
Count	138	139	140	135	131	138	138
#Blows	210440	211291	213905	205946	205899	213157	210994
Sum	191857.3	196321.1	196542.9	152533.3	185593.8	206344.2	203346.5
Average	0.91170	0.92915	0.91883	0.74065	0.90138	0.96804	0.96375
Stddev	0.15199	0.18849	0.09310	0.18510	0.27464	0.24012	0.11164
COV	0.16671	0.20287	0.10132	0.24991	0.30469	0.24805	0.11584
%n	0.87902	0.89947	0.90049	0.69885	0.85032	0.94539	0.93166
Median	0.93089	0.92671	0.93319	0.74539	0.89883	0.96686	0.99600

Observations:

- All versions of EDC are conservative when compared to PDA with Fixed Jc for Capacity estimates for both pile and concurrent blow comparisons. $0.17 < COV < 0.21$
- **UF EDC (Variable Jc) varies from 0.91 to 1.1 with later version less than 1.0; and $0.18 < COV < 0.22$;**
- **Top Compressive Stress, CSX varies from 0.92 to 0.93 with $COV < 0.1$**
- **Compression Tip Stress, CSB – 0.74 to 0.79 with $0.23 < COV < 0.25$**
- **TSX change from version earlier versions & 3.6 of 1.2 to 0.89 for version 3.72 to 3.761**

AVERAGE Values	Fixed/PDA	COV Fixed/PDA	UF/PDA	COV UF/PDA	CSX EDC/PDA	CSB EDC/PDA	COV CSB	TSX EDC/PDA
Earlier Version	0.97	0.18	1.09	0.18	0.93	0.79	0.23	1.20
Version 3.6	0.98	0.21	1.10	0.22	0.92	0.77	0.23	1.20
Version 3.73	0.91	0.18	0.93	0.19	0.93	0.74	0.25	0.90
Version 3.761	0.894	0.17	0.915	0.16	0.93	0.75	0.24	0.89

TASK 2: DATABASE vs. Static Testing

• Davisson Capacity Assessment

I-95 Test Pile Top and Tip Force VS Displacement

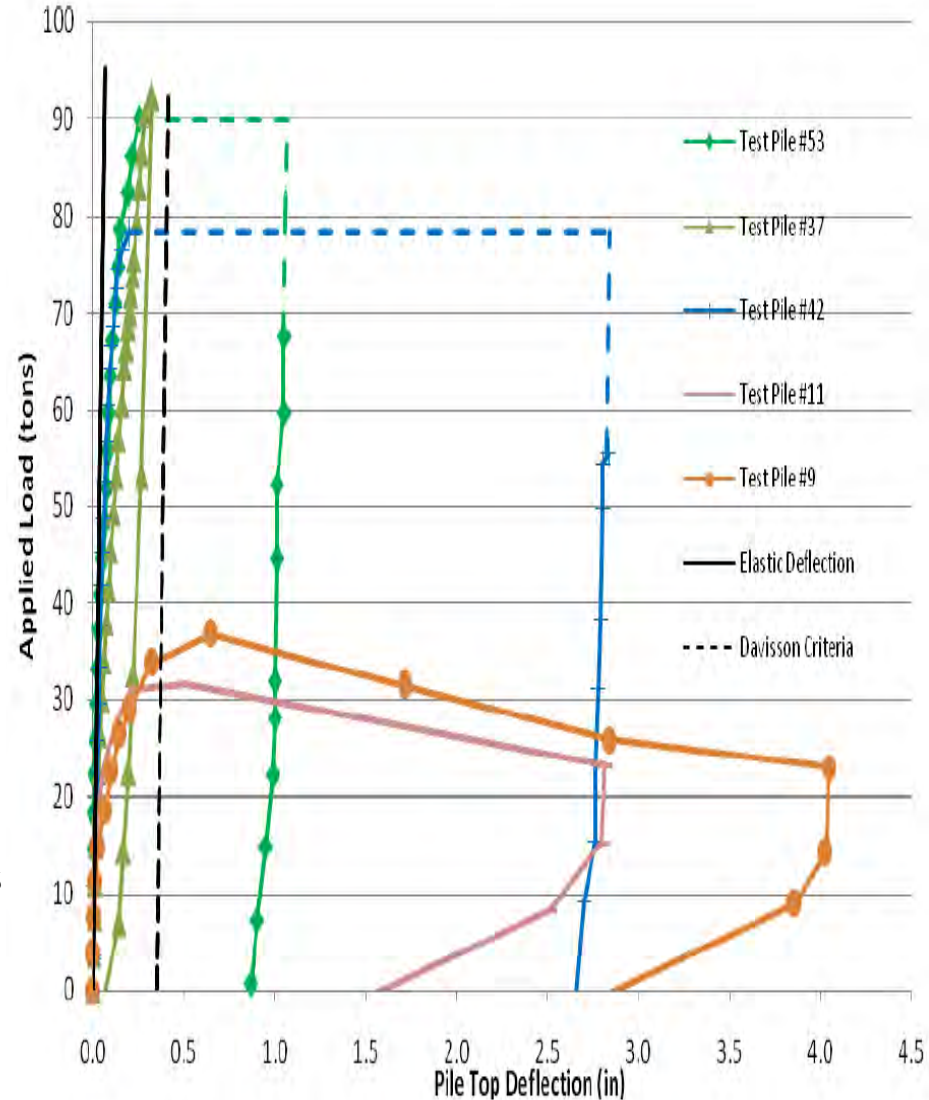
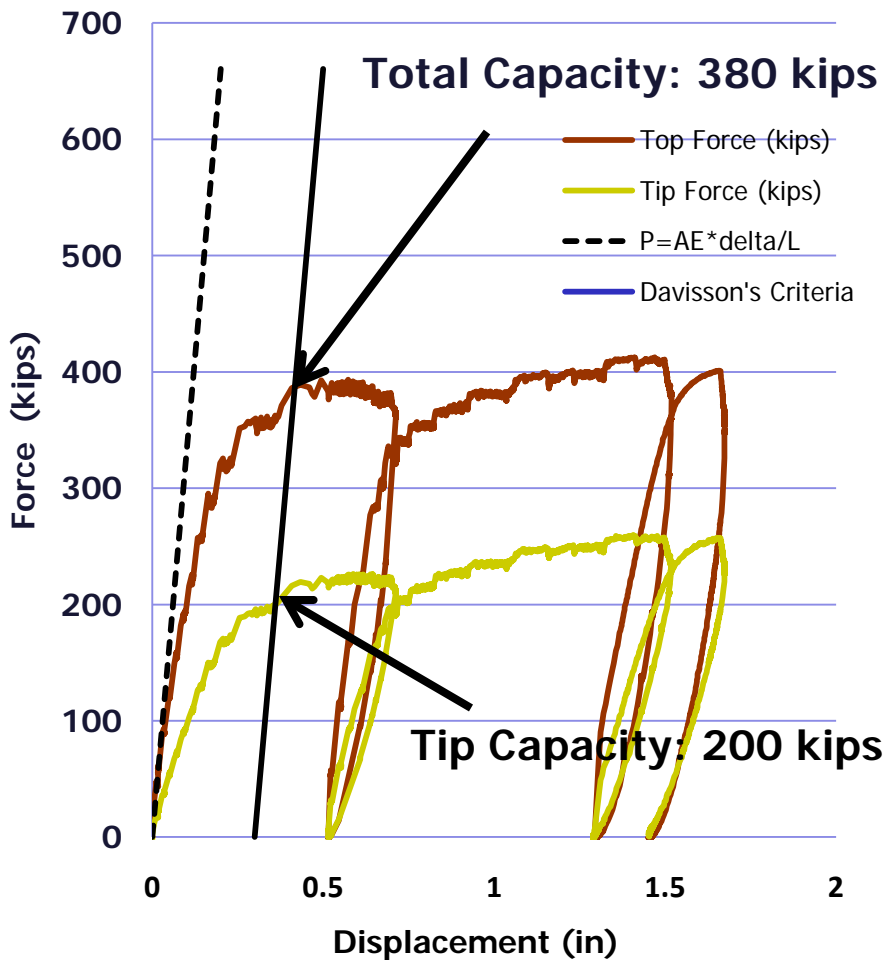

Comparison of Measured and Predicted Forces

Pile No.	FDOT Total Capacity (kips)	FDOT Tip Capacity (kips)	FDOT Skin Capacity (kips)	UF Method Total Capacity (kips) (version 3.72)	UF Method Tip Capacity (kips) (version 3.72)	UF Method Skin Capacity (kips) (version 3.72)
Dixie Highway End Bent 1	430	296	134	448	349	99
Dixie Highway Pier 8	380	200	180	470	270	220
Caminida Bay Bent 1	540	144.8	395.2	574	94	480
Caminida Bay Bent 7	625	80	545	587	67	520
I-95 Version 3.5	380	200	180	369	263	106

Comparison of Measured and Predicted Forces

Pile No.	FDOT Skin Capacity (kips)	UF Method Skin Capacity (kips) (version 3.6)
Dixie Highway Pier 4	212	171
5 th St Bascule Bridge Pier 2 Pile 37	185	220
5 th St Bascule Bridge Pier 2 Pile 53	180	200
5 th St Bascule Bridge Pier 3 Pile 9	68	150
5 th St Bascule Bridge Pier 3 Pile 42	153	215

Future Monitoring:
Louisiana
Mississippi

Comparison of (FDOT) Measured and EDC Predicted Forces (20 Values)

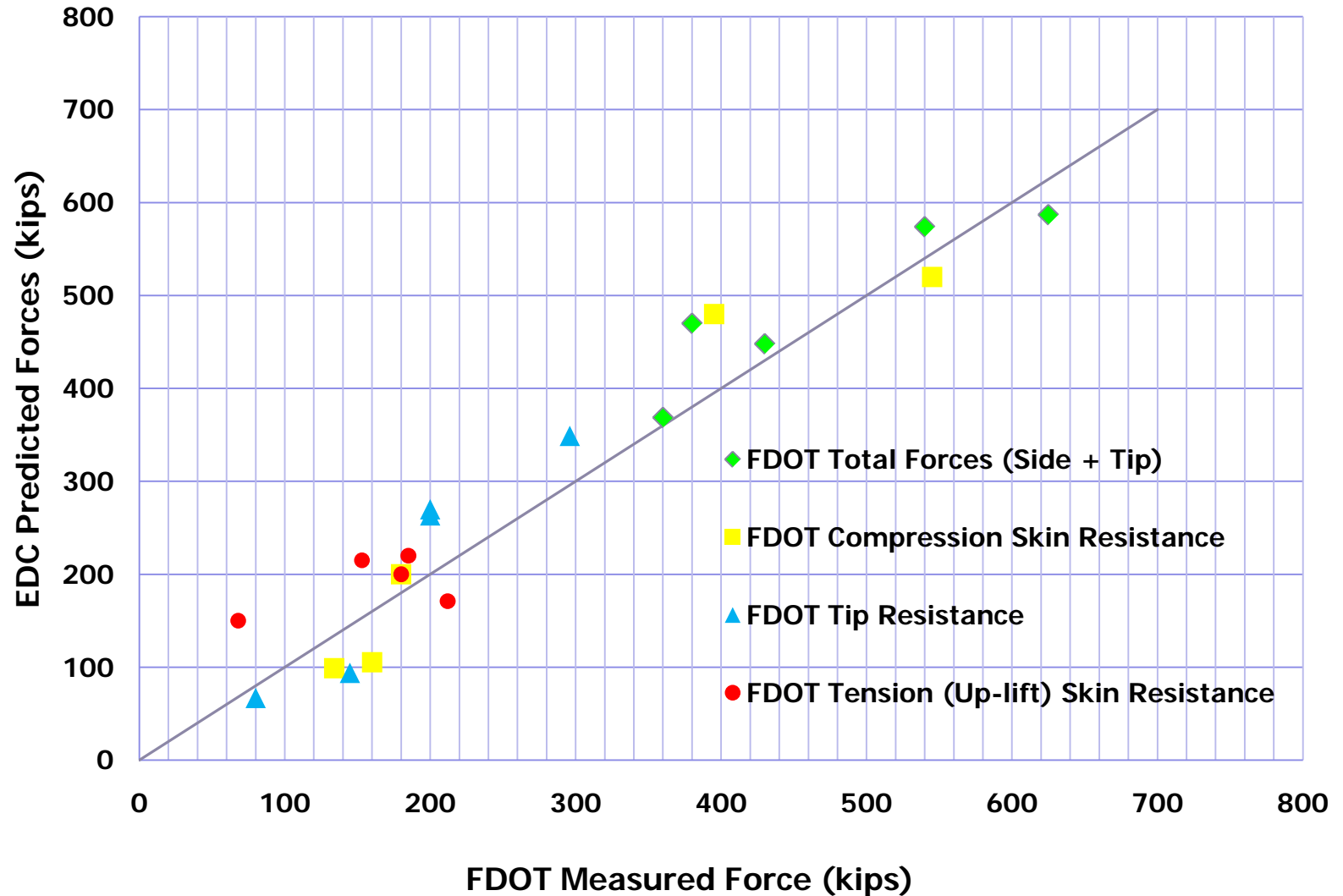

Task 3: Improve Pile Freeze and Pile Capacity

Improved Pile Tip Capacity:

Tip Accelerometer

Tip Strain Gage

- Use of Force Equilibrium and Energy to Assess Static Tip Resistance

$$F_{inertia} (m \ddot{x}) + F_{damping} (c \dot{x}) + F_{static} (k x) = P(t)$$

Force Equilibrium



$$\int (m \ddot{x} + c \dot{x} + k x) dx = \int P(t) dx$$

Energy Equilibrium

$$\int_t^{t+T} (m \ddot{x} + c \dot{x} + k x) \dot{x} dt = \int_t^{t+T} P(t) \dot{x} dt$$

accel
 Vel.
 Dis.
 strain
 mass viscous damp stiffness

In Time Domain

Algorithm (1-2 sec per blow)

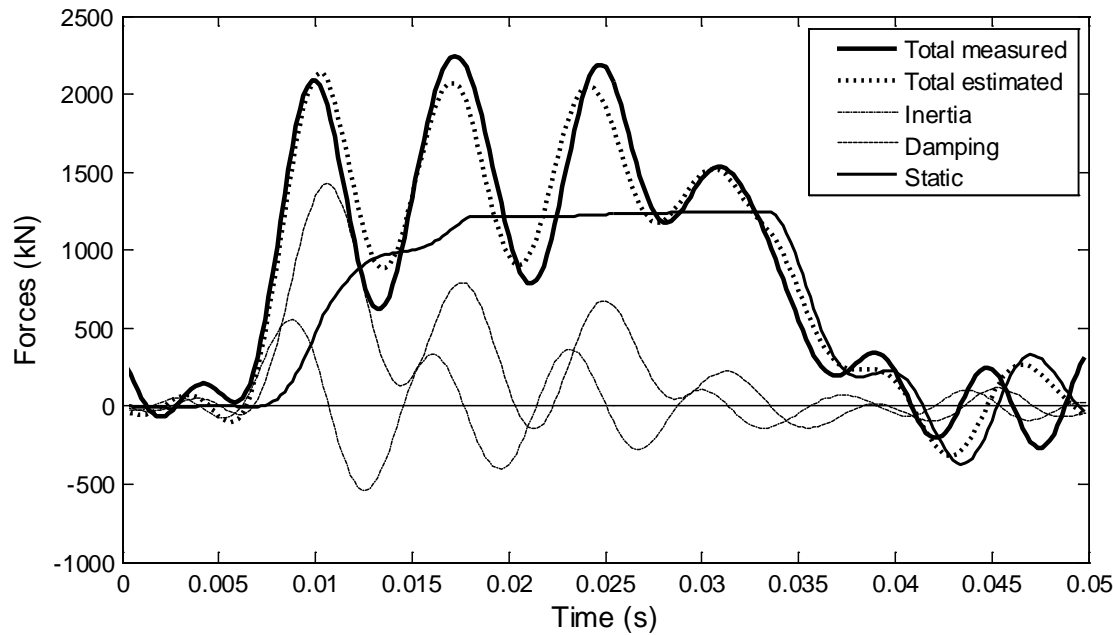

Dixie Highway
24" x 50'

Matching Forces:
Inertia, Damping &
Static

Conserving Energy:
Inertia, Damping &
Static

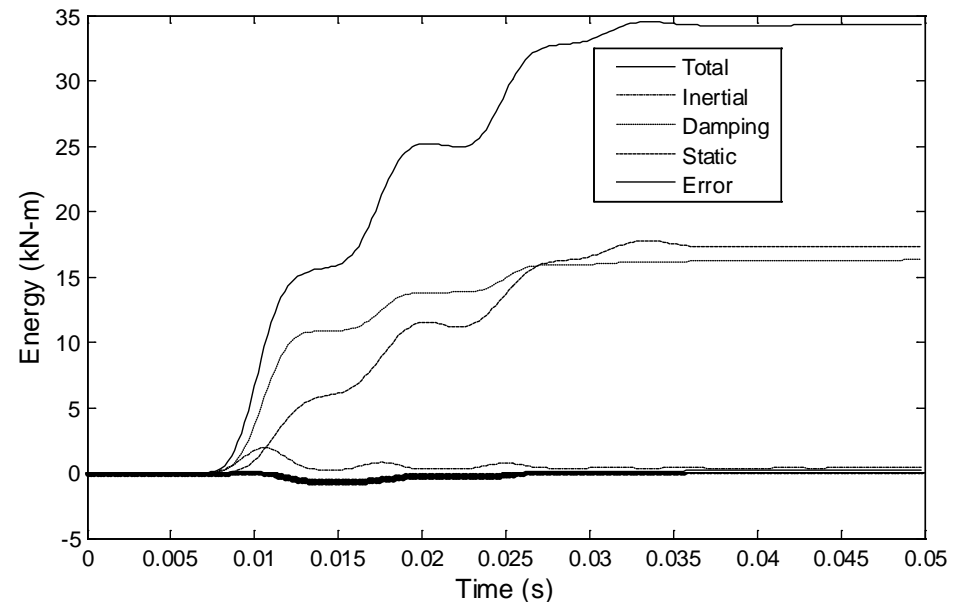

Dixie Pier 8 (Pre and Post Load Test)

Civil & Coastal
Engineering

Comparison:
Measured vs. Energy
And CAPWAP

a)

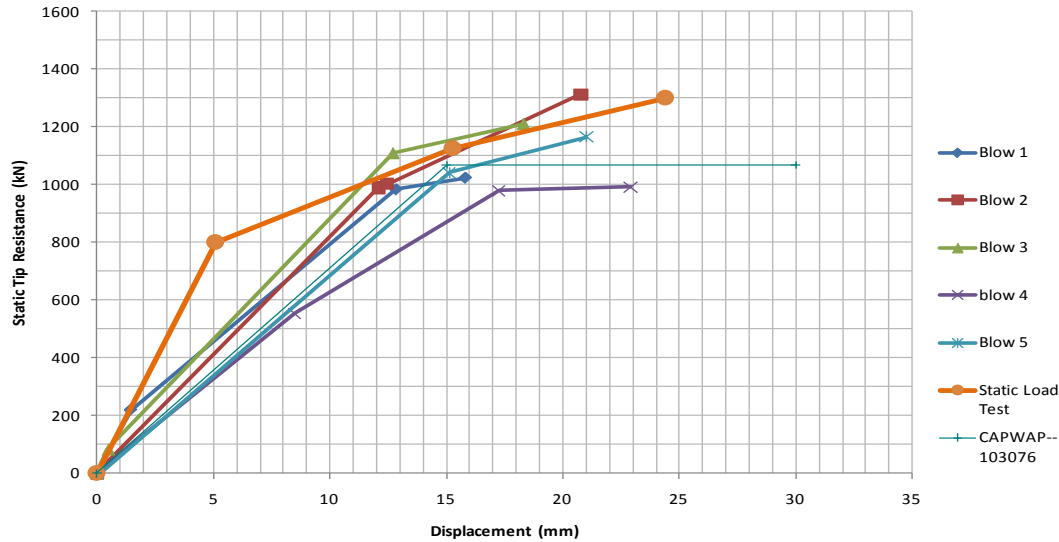

b)

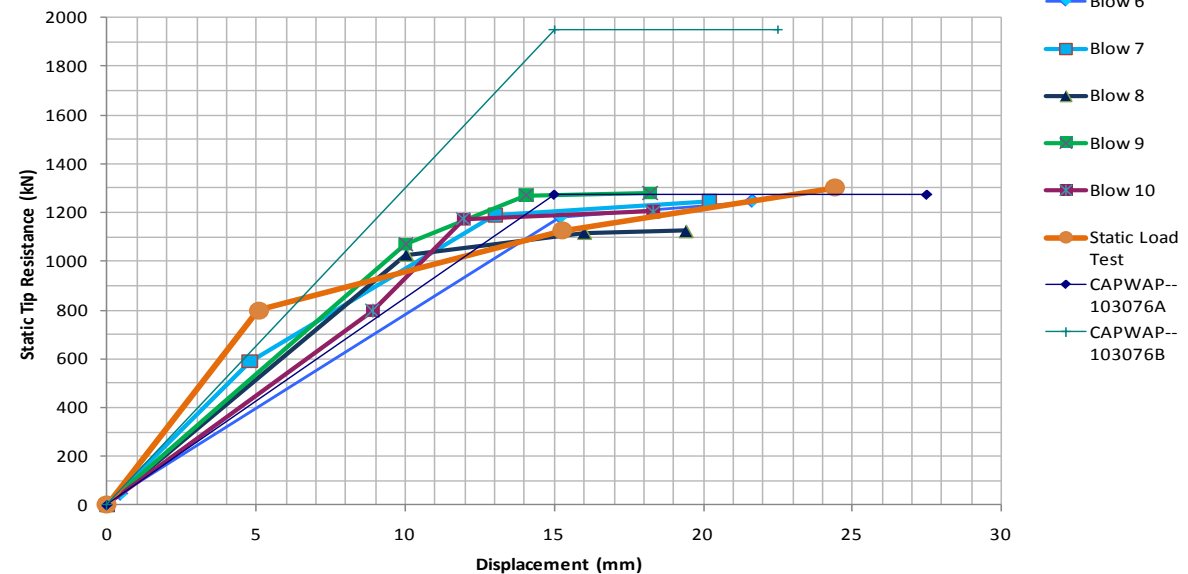

Dixie Bent 1 (Pre Load Test)

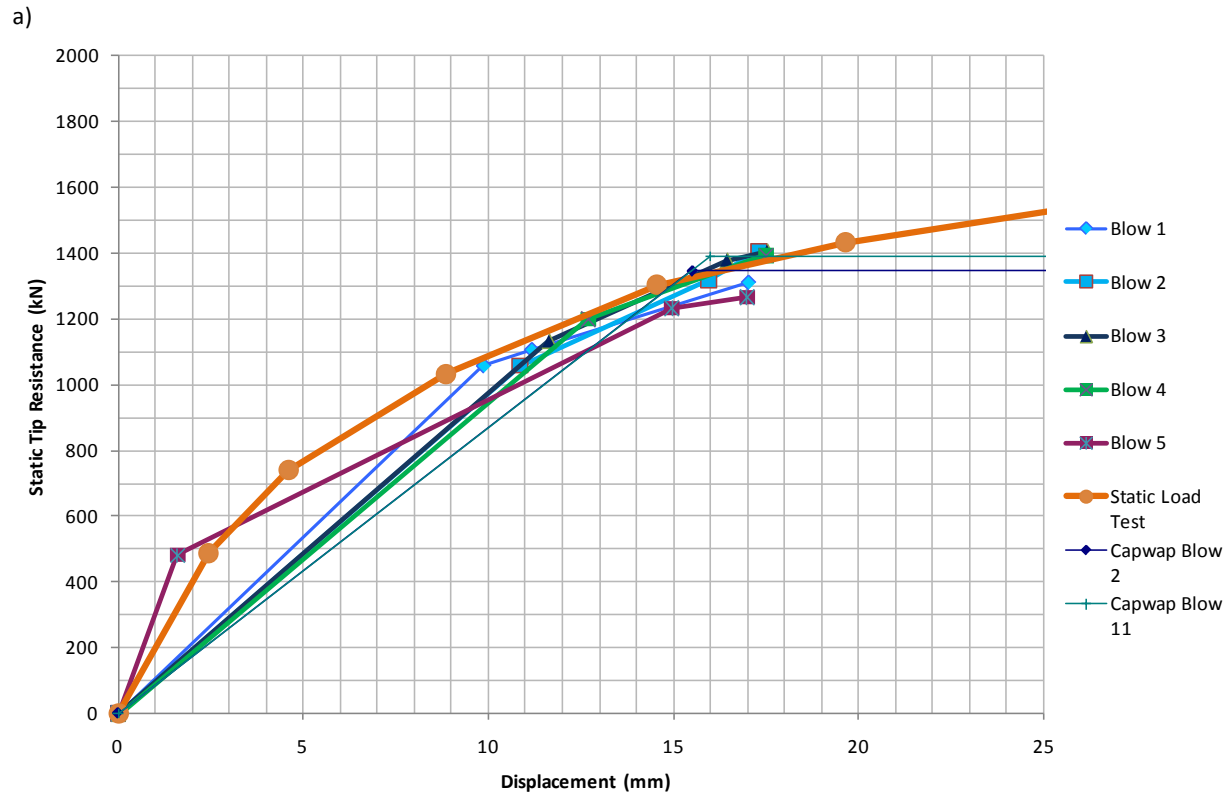

Comparison:
Measured vs. Energy,
And CAPWAP

Caminida Bay Louisiana

Civil & Coastal
Engineering

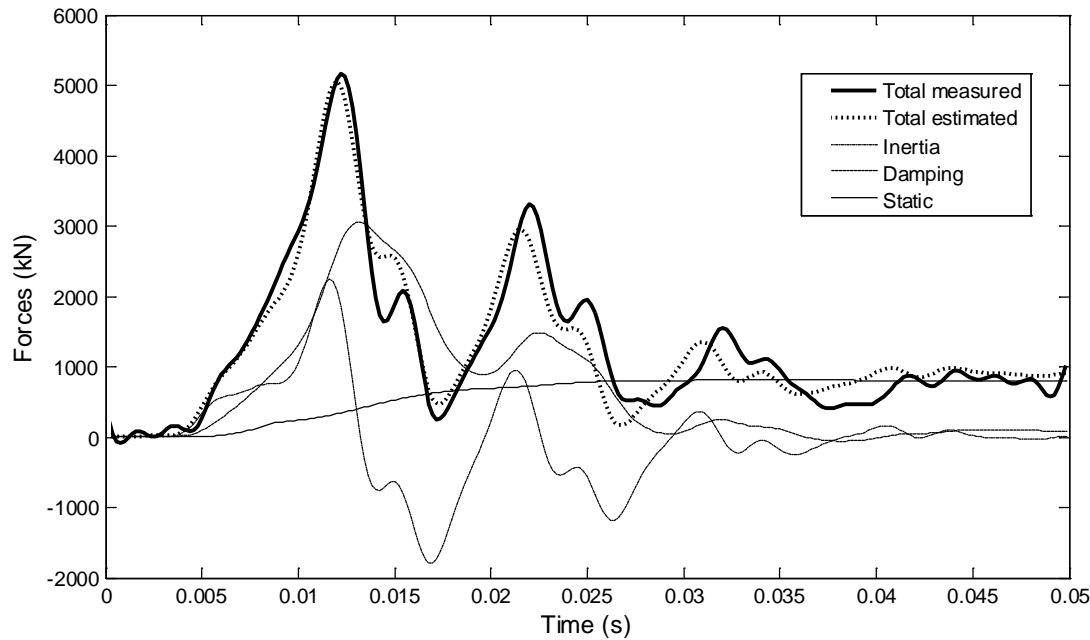

30" x 71' Sand
Silt & Clay

Matching Forces:
Inertia, Damping &
Static

Conserving Energy:
Inertia, Damping &
Static

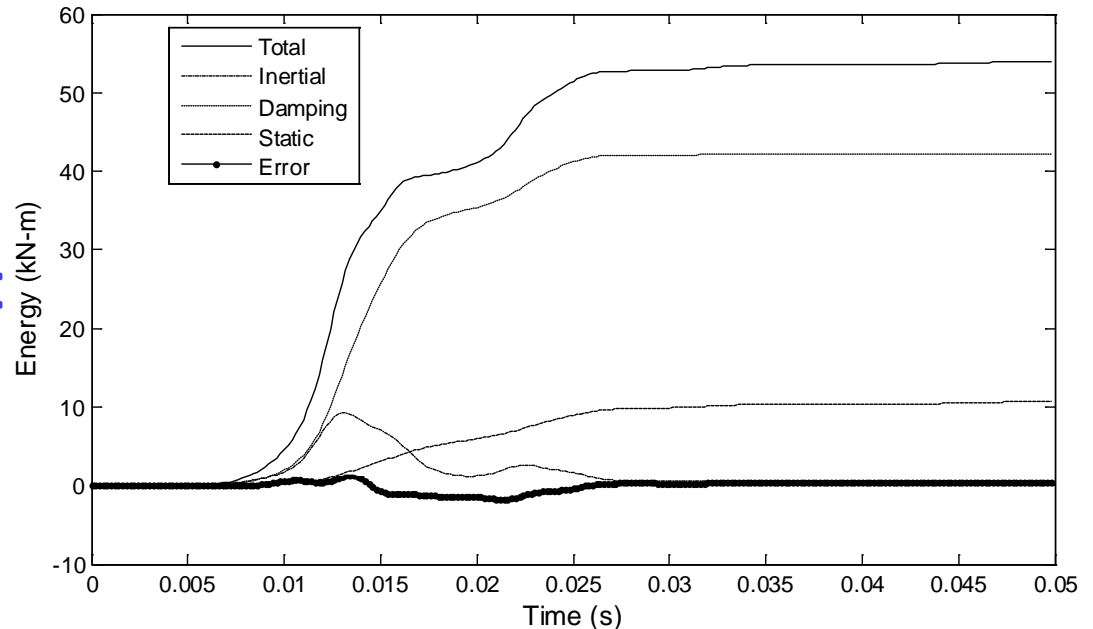

Caminida Bent 7 (EOD and 1 week BOR)

Comparison:
Measured vs.
Energy,
And CAPWAP

<20% increase
EOD to BOR
"Freeze"

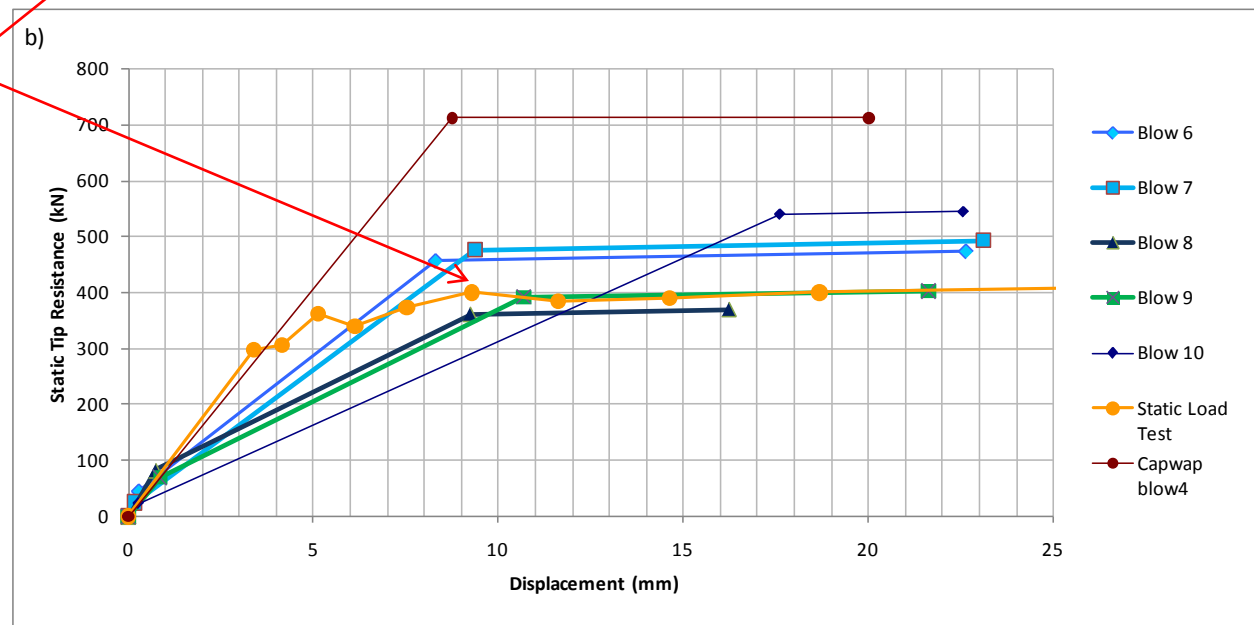
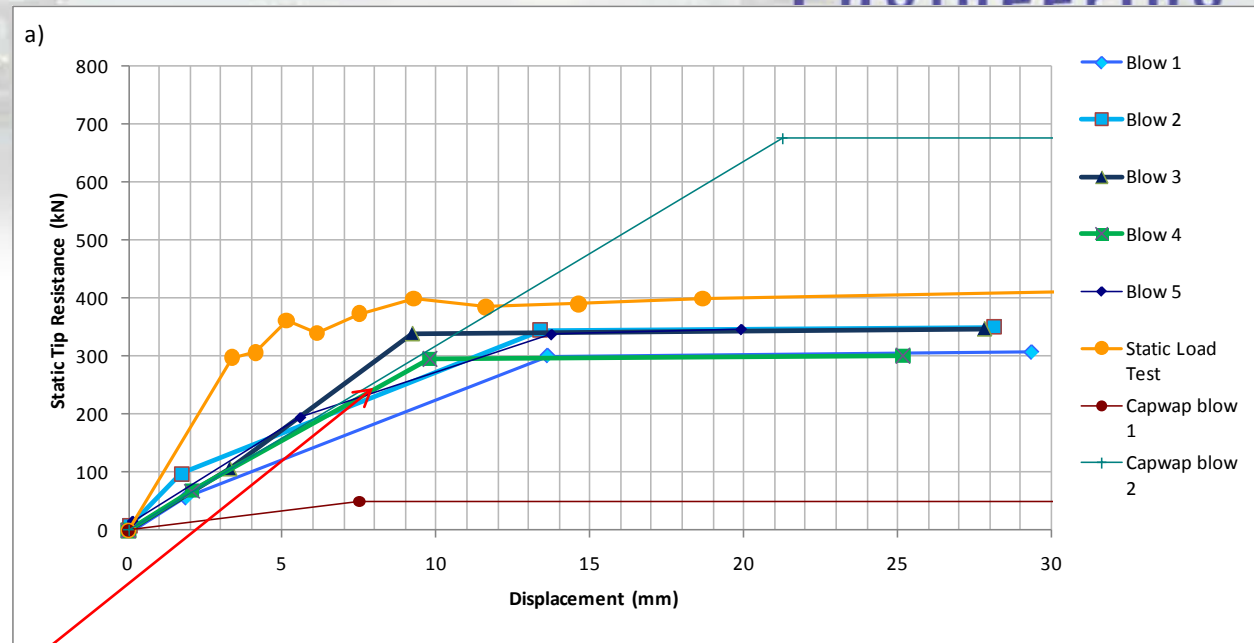

Caminida Bent 1 (EOD and 1 week BOR)

Comparison:
Measured vs.
Energy,
And CAPWAP

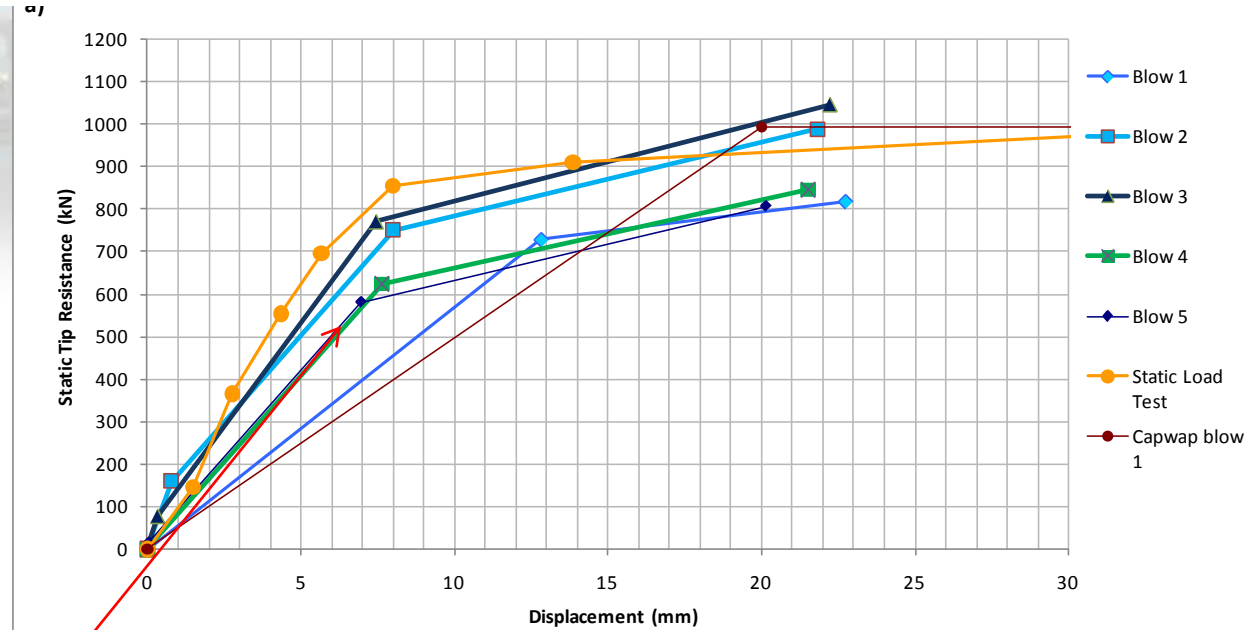

<20% increase
EOD to BOR
"Freeze"

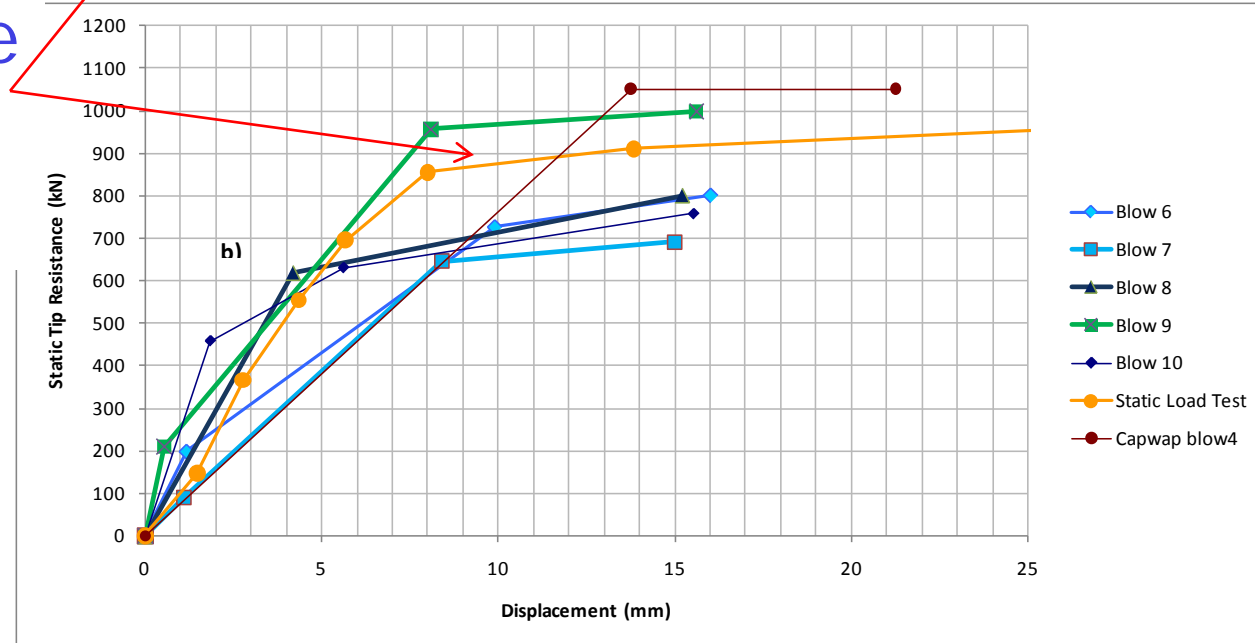

Side Friction: EOD vs. BOR

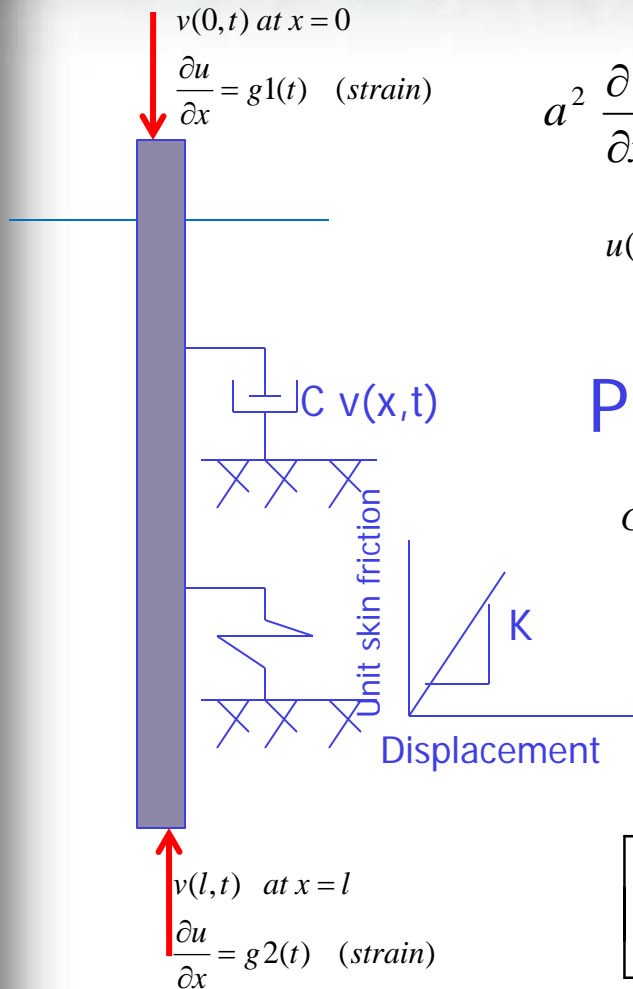

$$a^2 \frac{\partial^2 u}{\partial x^2} = \frac{\partial^2 u}{\partial t^2} + c \frac{\partial u}{\partial t} + b u(x, t).$$

$$u(x, t) = -a^2 \int_0^t g1(\tau) G(x, 0, t - \tau) d\tau + a^2 \int_0^t g2(\tau) G(x, l, t - \tau) d\tau$$

$$= -a^2 [g1 * G(x, 0, t) - g2 * G(x, l, t)]$$

Predicted Green's Function:

$$G(x, \xi, t) = \exp\left(-\frac{1}{2} ct\right) \left[\frac{\sin\left(t\sqrt{|p|}\right)}{l\sqrt{|p|}} + \frac{2}{l} \sum_{n=1}^{\infty} \cos(\mu_n x) \cos(\mu_n \xi) \frac{\sin\left(t\sqrt{a^2 \mu_n^2 - p}\right)}{\sqrt{a^2 \mu_n^2 - p}} \right], \mu_n = \frac{\pi n}{l}$$

$$p = b + \frac{1}{4} c^2$$

Measured Green's Function:

$$\begin{bmatrix} G1(\omega) \\ G2(\omega) \end{bmatrix} = \frac{1}{a^2} \begin{bmatrix} -g1(\omega) & g2(\omega) \\ g2(\omega) & -g1(\omega) \end{bmatrix}^{-1} \begin{bmatrix} v(0, \omega) \\ v(l, \omega) \end{bmatrix}$$



Automatic
Algorithm
Requires 1-2secs
Per blow
May be Used
"Real Time"

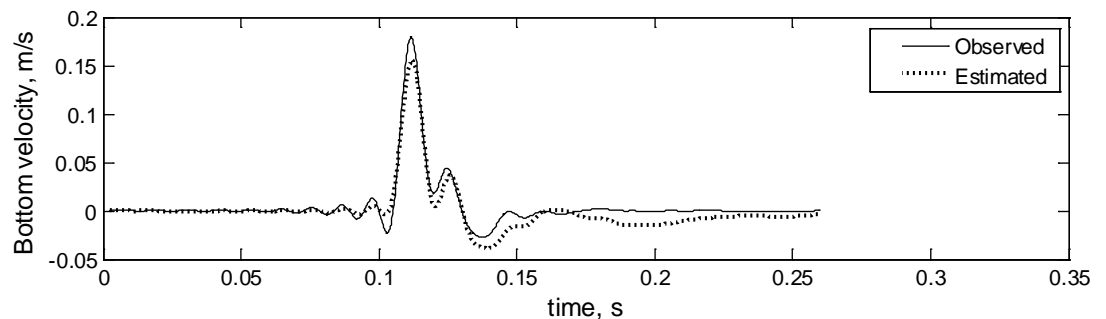
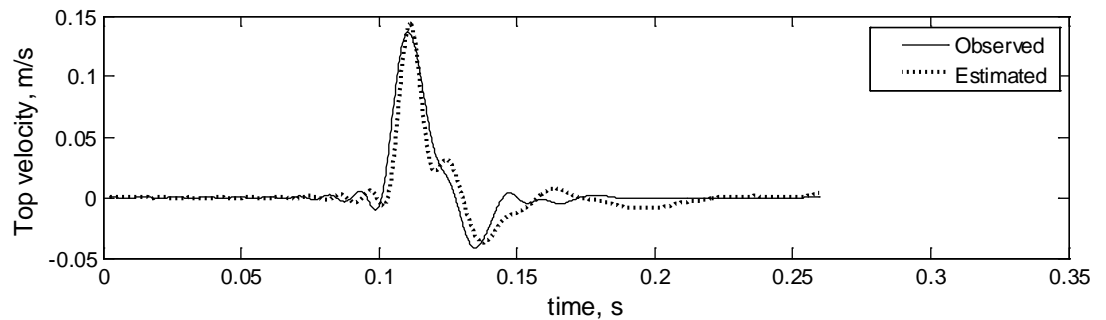
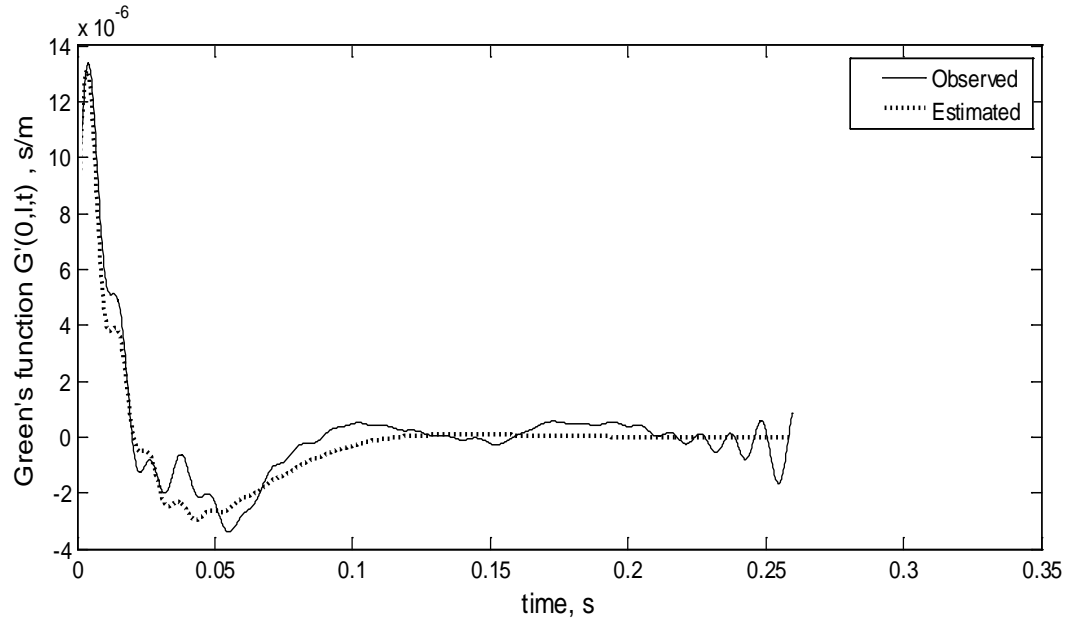

Dixie Highway End Bent 1



EOD vs. BOR
1 Week later

60% Increase
In Skin Friction

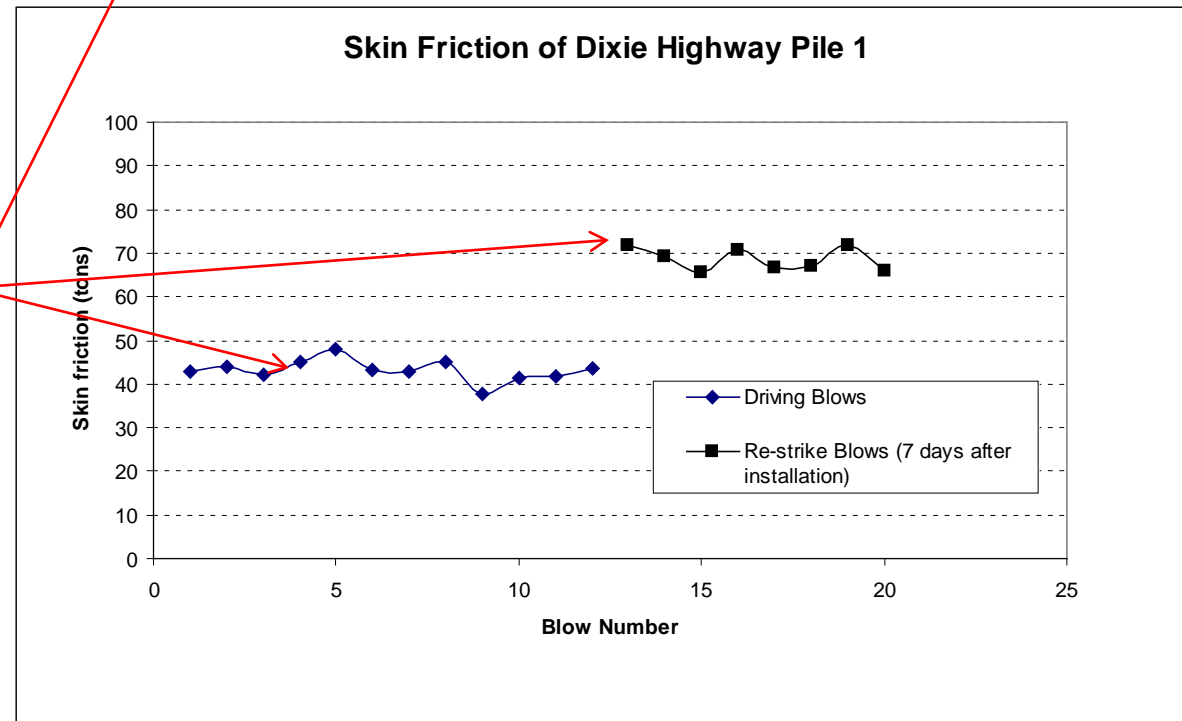
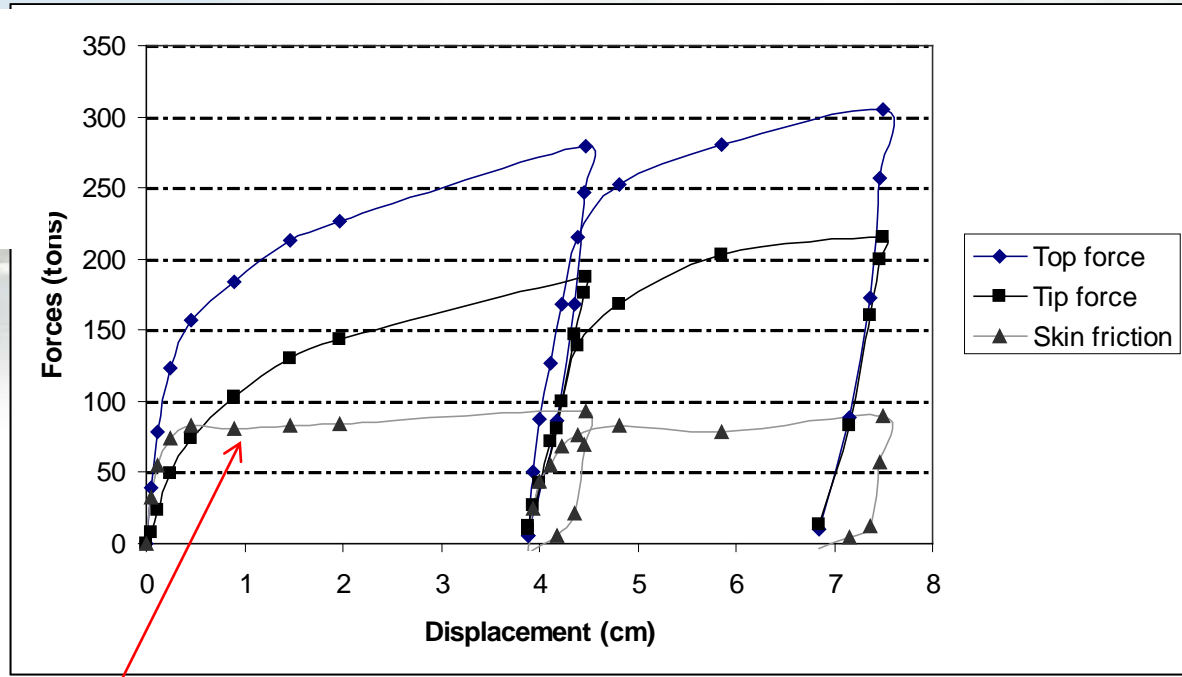

Dixie Highway Pier 8



EOD vs. BOR
1 Week later

60% Increase
In Skin Friction

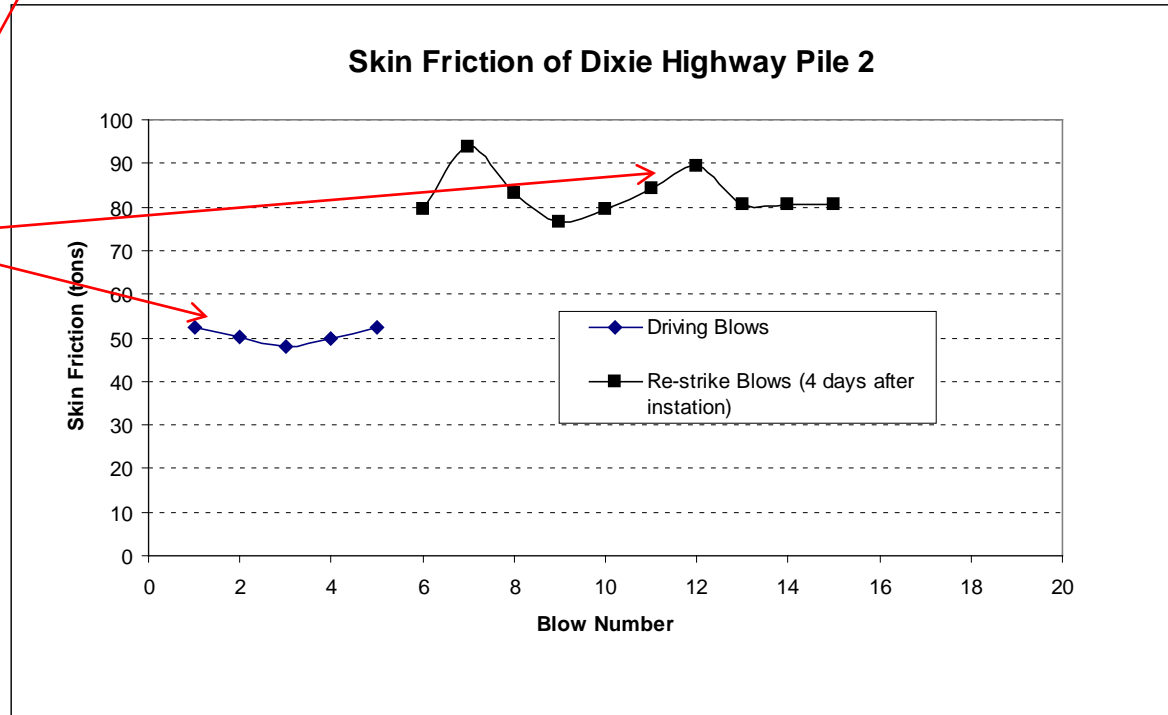
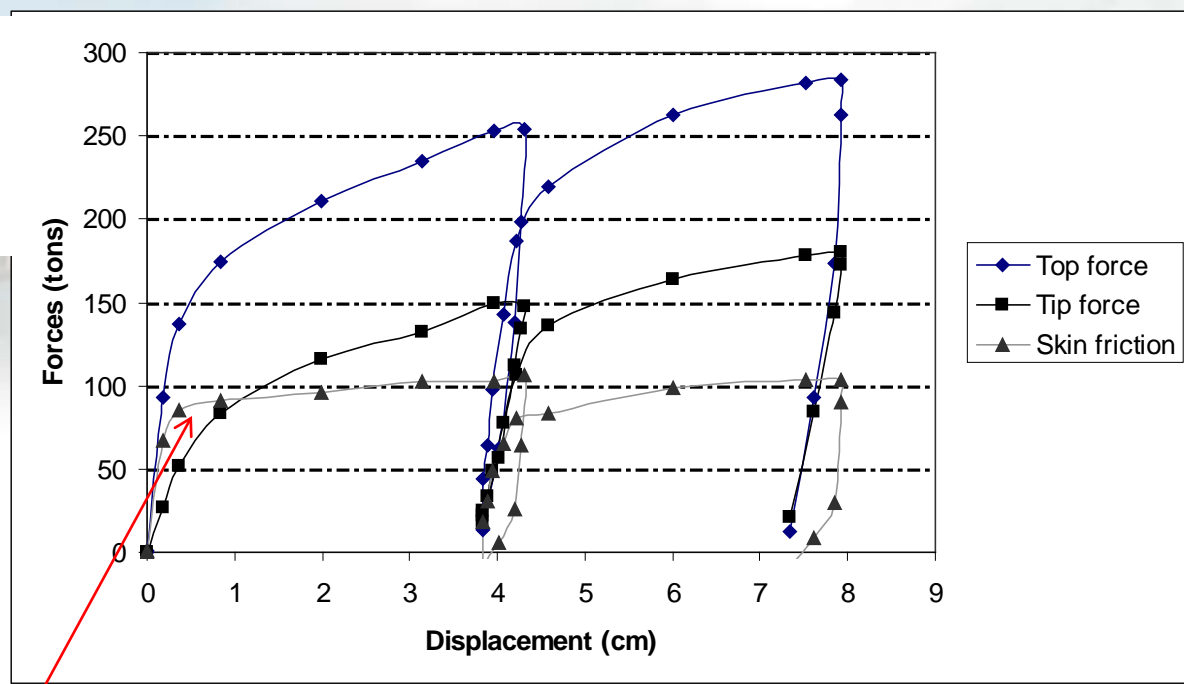

Caminida Bay Pile 1

EOD vs. BOR
1 week later

55% Increase
In Skin Friction

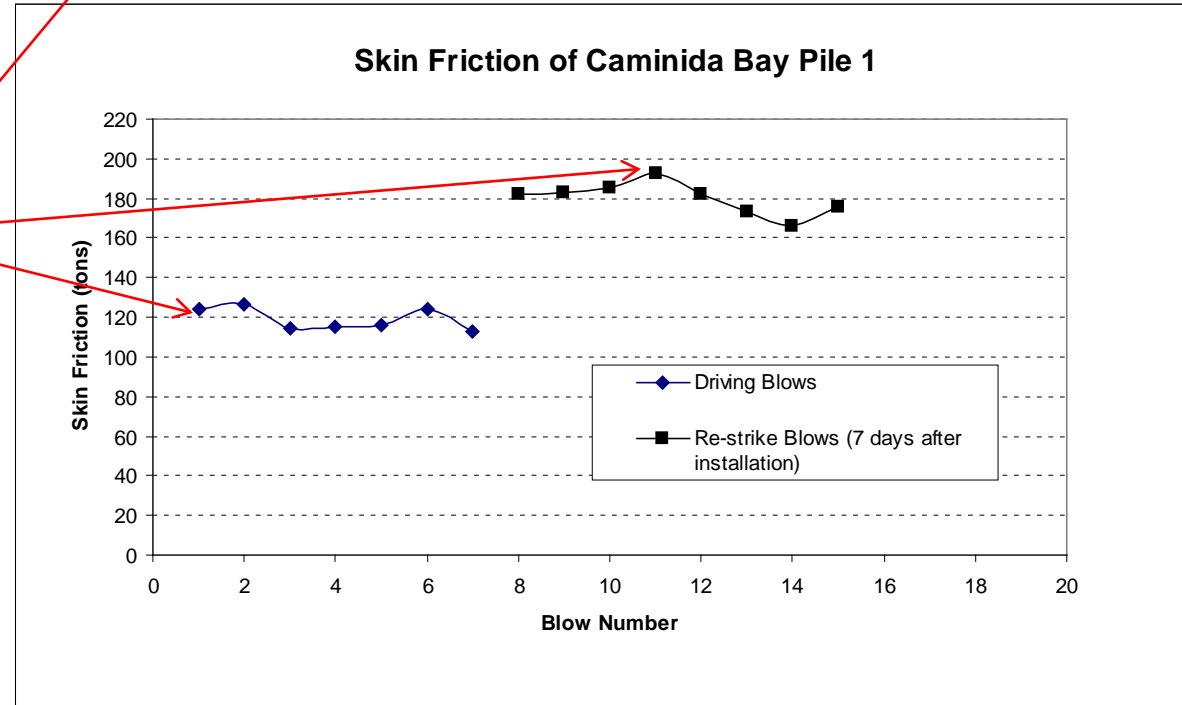
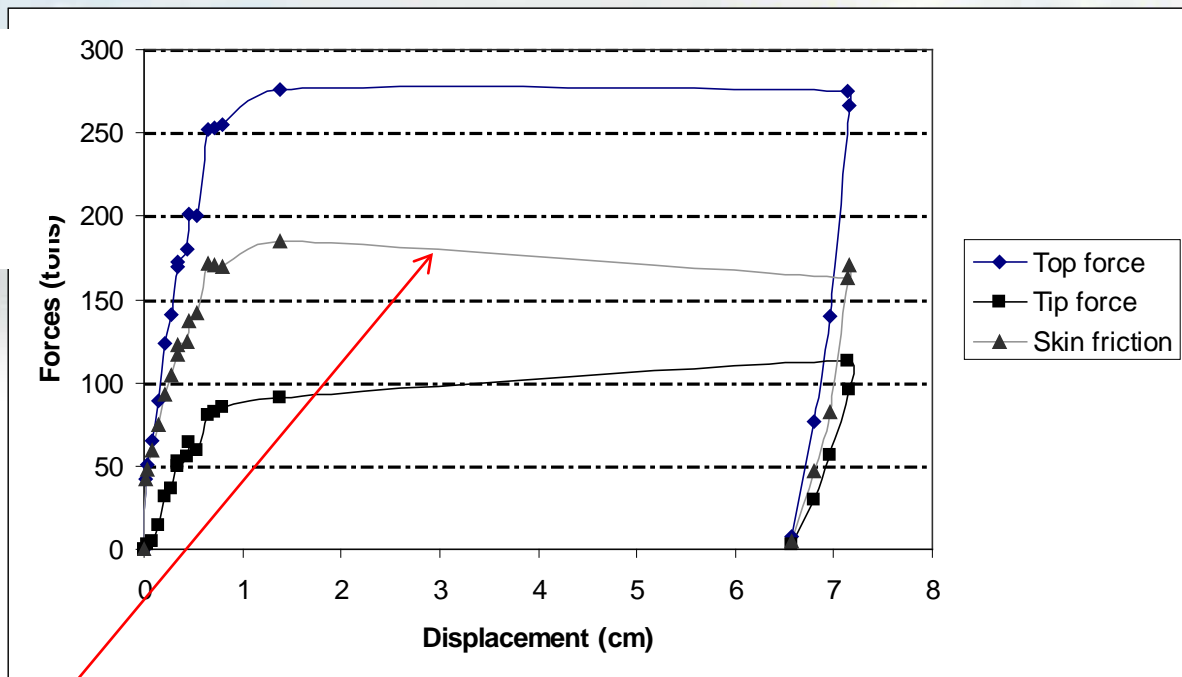

Caminida Bay Pile 2

EOD vs. BOR
1 month later

Increase
In Skin Friction

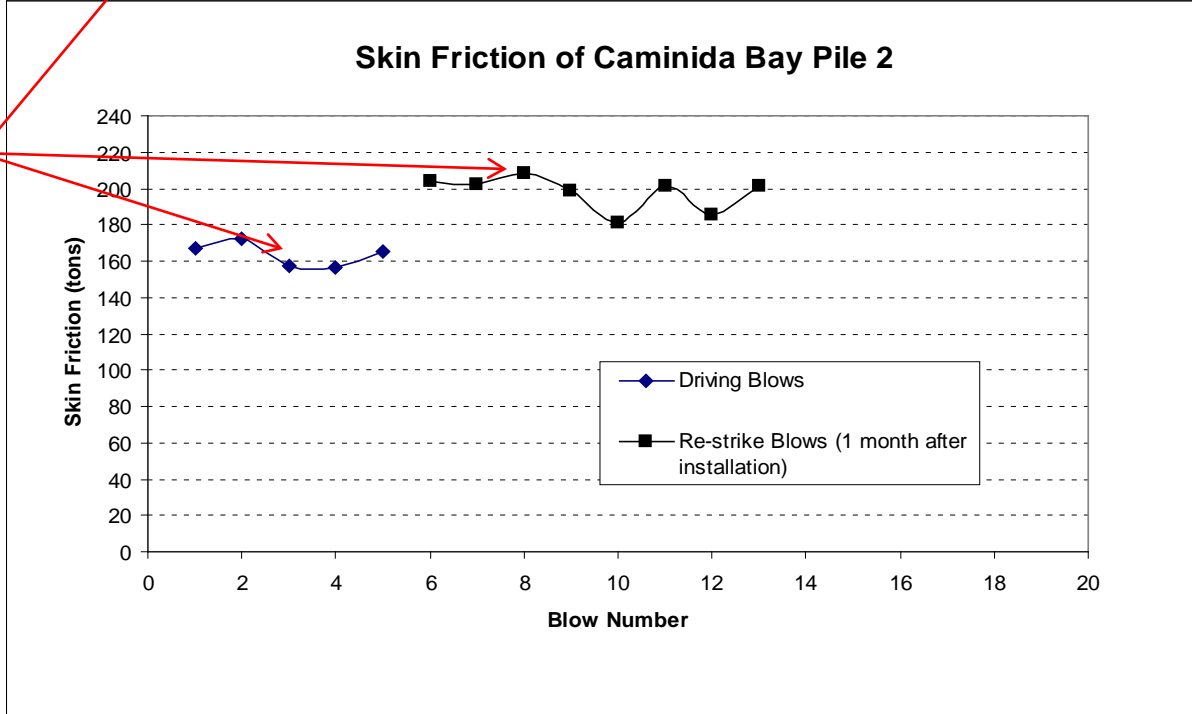
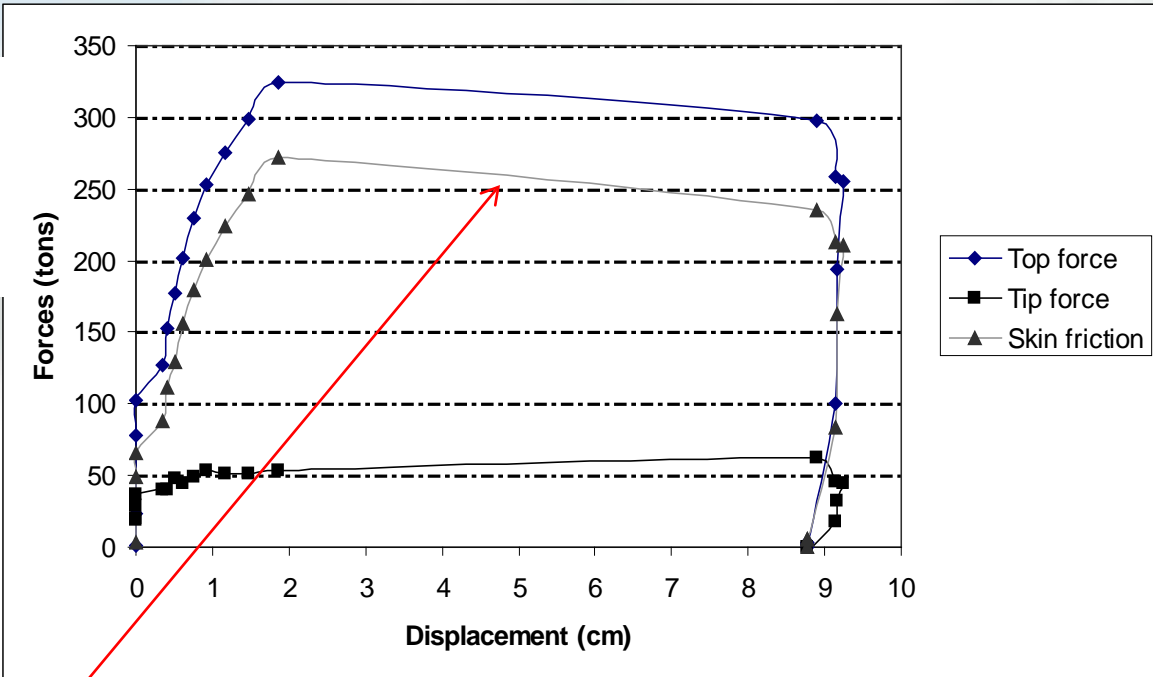

Nonlinear Skin Friction and Segments

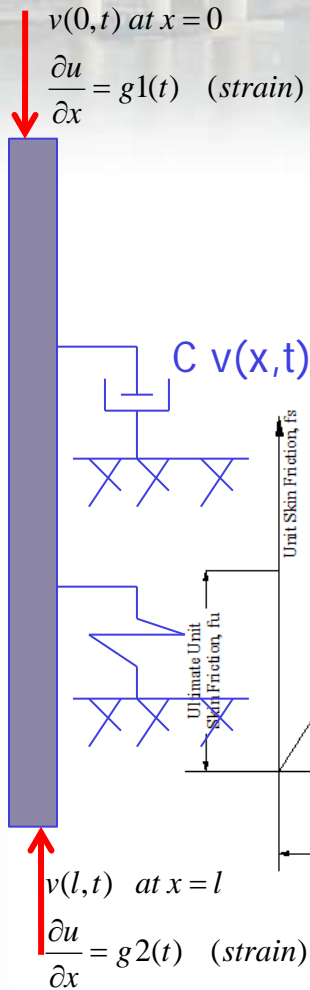

$$a^2 \frac{\partial^2 u}{\partial x^2} = \frac{\partial^2 u}{\partial t^2} + c \frac{\partial u}{\partial t} + b.$$

where

$$a^2 = \frac{E}{\rho} \quad b = \frac{4 f_s}{\rho B} \quad c = \frac{4 C_r \rho_s}{B \rho}$$

$$\left. \frac{\partial^2 u}{\partial x^2} \right|_{i,j} = \frac{U_{i+1,j} - 2U_{i,j} + U_{i-1,j}}{\Delta x^2},$$

$$\left. \frac{\partial^2 u}{\partial t^2} \right|_{i,j} = \frac{U_{i,j+1} - 2U_{i,j} + U_{i,j-1}}{\Delta t^2},$$

$$\left. \frac{\partial u}{\partial t} \right|_{i,j} = \frac{U_{i,j+1} - U_{i,j-1}}{2\Delta t},$$

$$\left. \frac{\partial u}{\partial x} \right|_{i,j} = \frac{U_{i+1,j} - U_{i-1,j}}{2\Delta x}, \quad i = 1, 2, \dots, N; \quad j = 2, 3, \dots, n$$

$$U_{i,j+1} = \frac{a^2 \frac{U_{i+1,j} - 2U_{i,j} + U_{i-1,j}}{\Delta x^2} - \frac{U_{i,j-1} - 2U_{i,j} + U_{i,j+1}}{\Delta t^2} + c_i \frac{U_{i,j-1} - U_{i,j+1}}{2\Delta t} - b_{i,j}}{\frac{1}{\Delta t^2} + \frac{c_i}{2\Delta t}},$$

where

$$b_{i,j} = \begin{cases} k_i U_{i,j} & \text{for loading with } U_{i,j} \leq q_i \\ k_i q_i & \text{for loading with } U_{i,j} > q_i \\ k_i q_i - \bar{k}_i [\max(U_{i,1..j}) - U_{i,j}] & \text{for unloading} \end{cases}$$

$v(0,t)$ at $x=0$
 $\frac{\partial u}{\partial x} = g1(t)$ (strain)

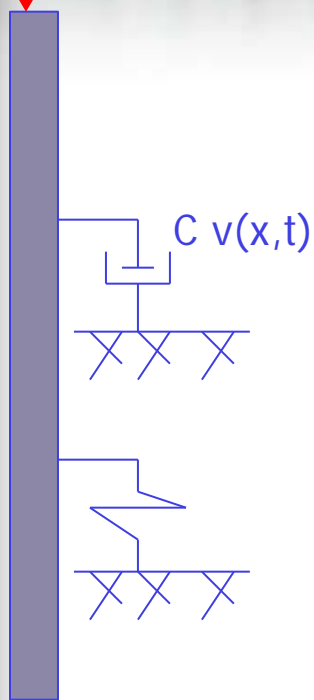

$v(l,t)$ at $x=l$
 $\frac{\partial u}{\partial x} = g2(t)$ (strain)

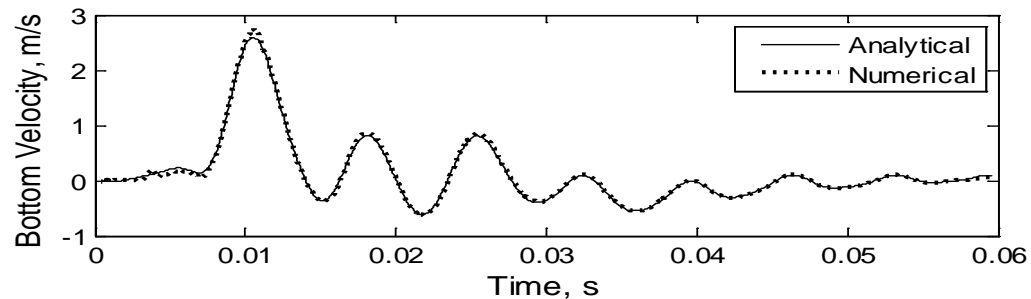
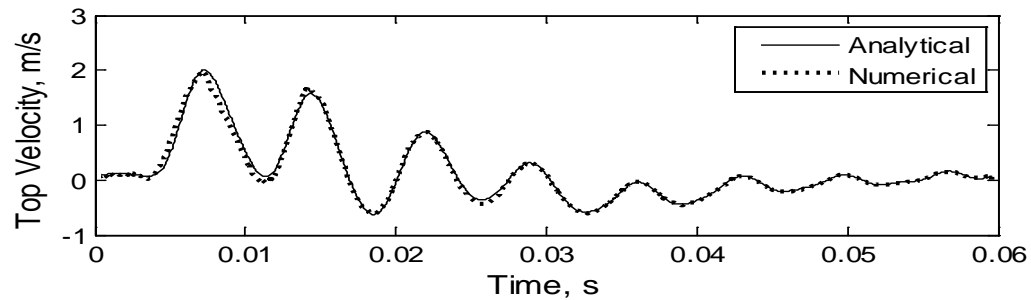
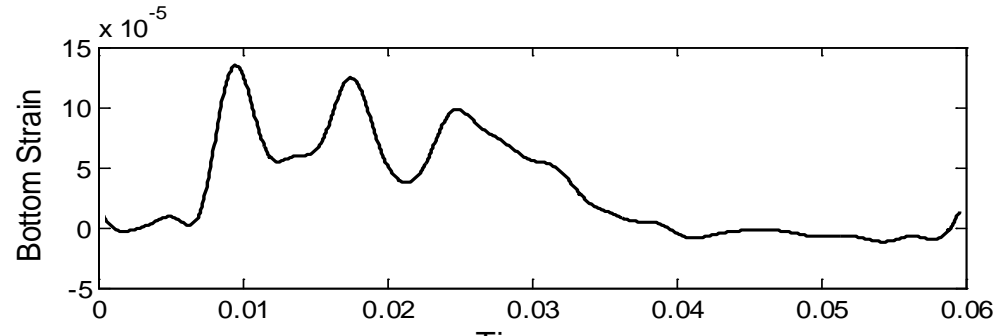
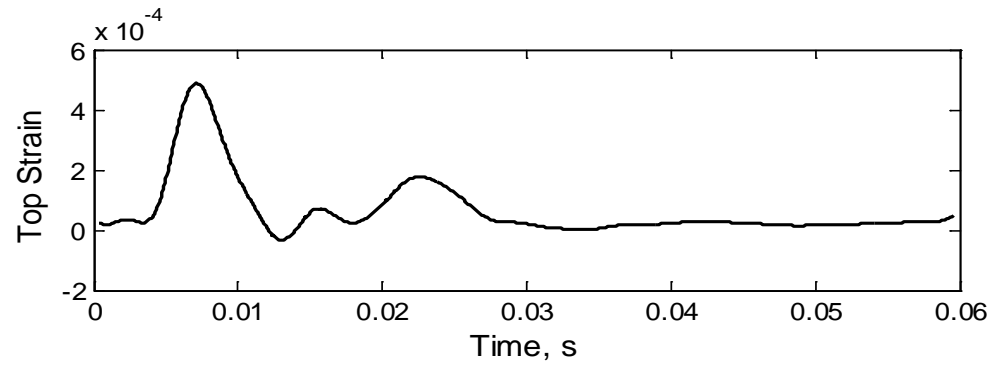

Skin Friction of Dixie Highway, Pile 1

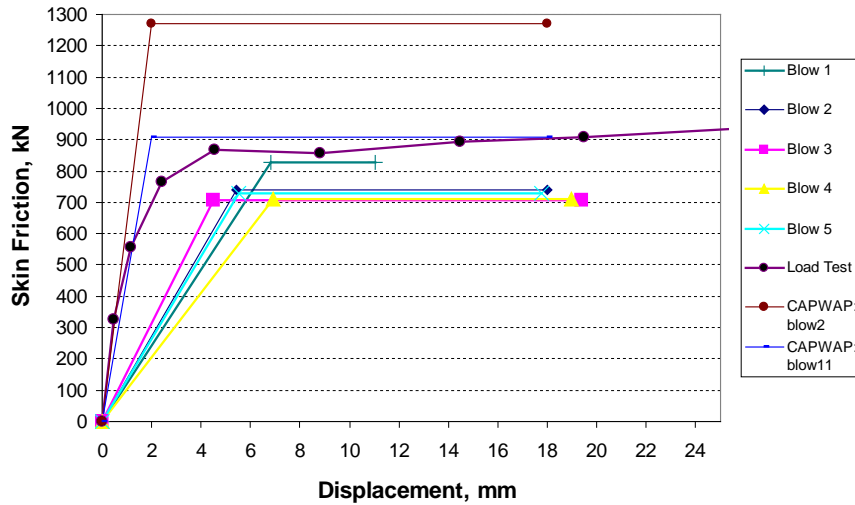

Skin Friction of Dixie Highway, Pile 2

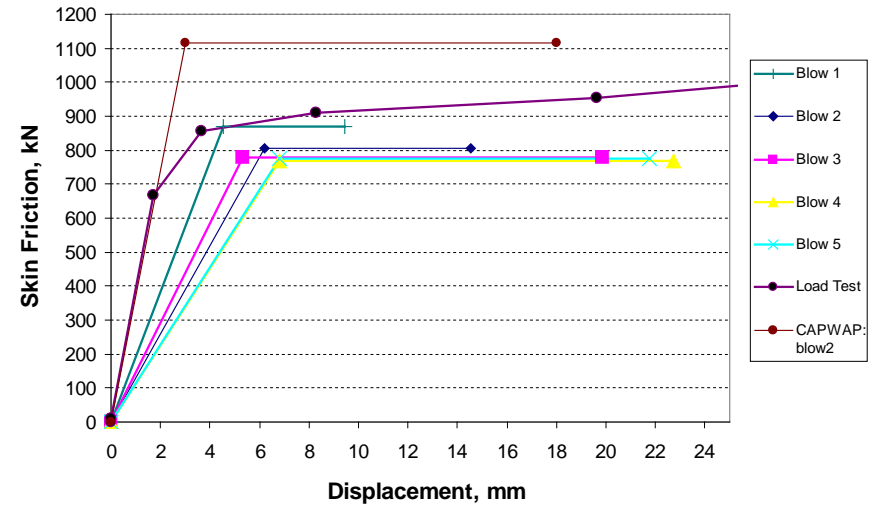

Skin Friction of Caminida Bay, Pile 1

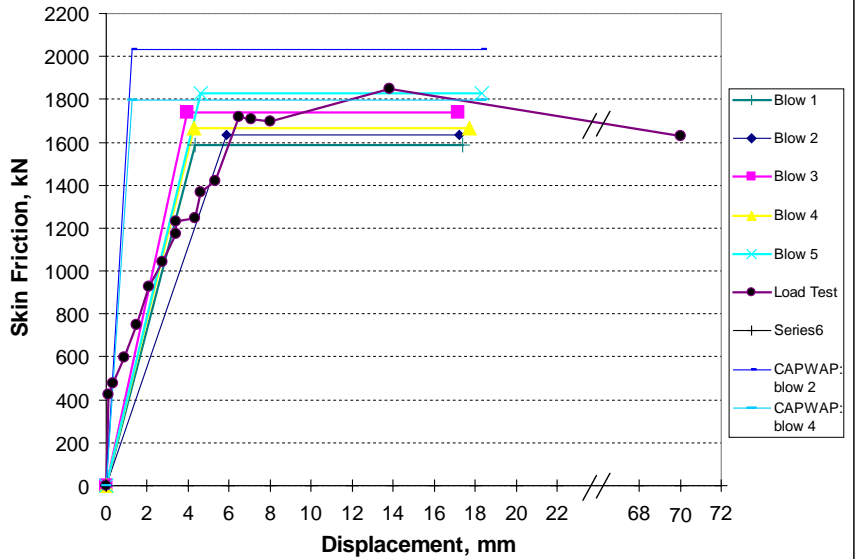

Skin Friction of Caminida Bay, Pile 2

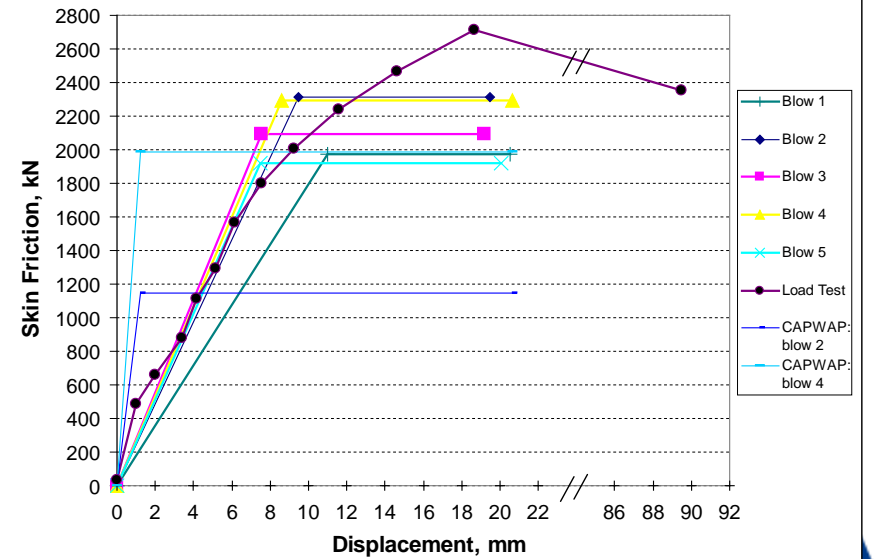

Estimation of Skin Friction Changes with Time

$$Q(t) = Q_0(t_0) \left[1 + A \log_{10} \left(\frac{t}{t_0} \right) \right]$$

Bullock 2005
 $0.1 < A < 0.5$

EOD for Tip and BOR
 For Side Friction

Skin Friction of Dixie Highway Bent 1, Pile 1

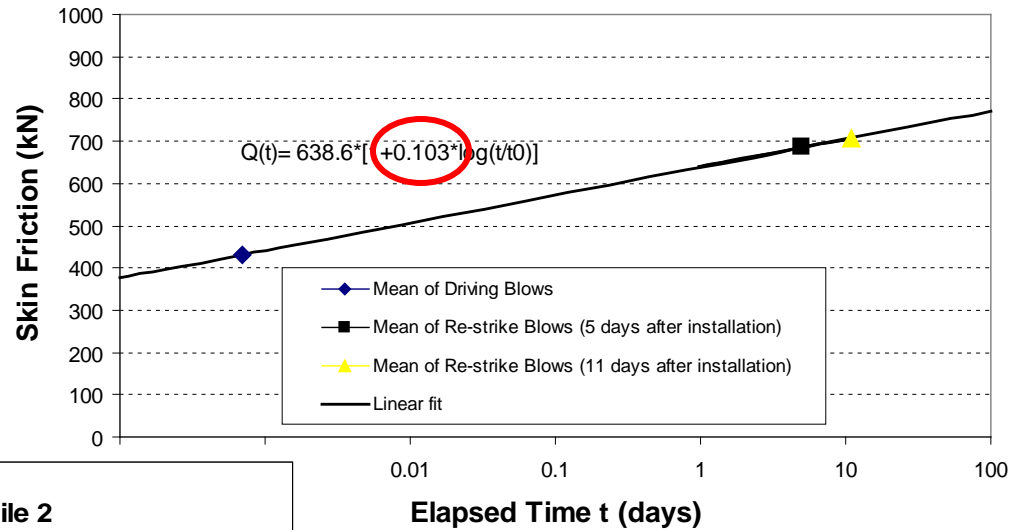

Skin Friction of Dixie Highway, Bent 7, Pile 2

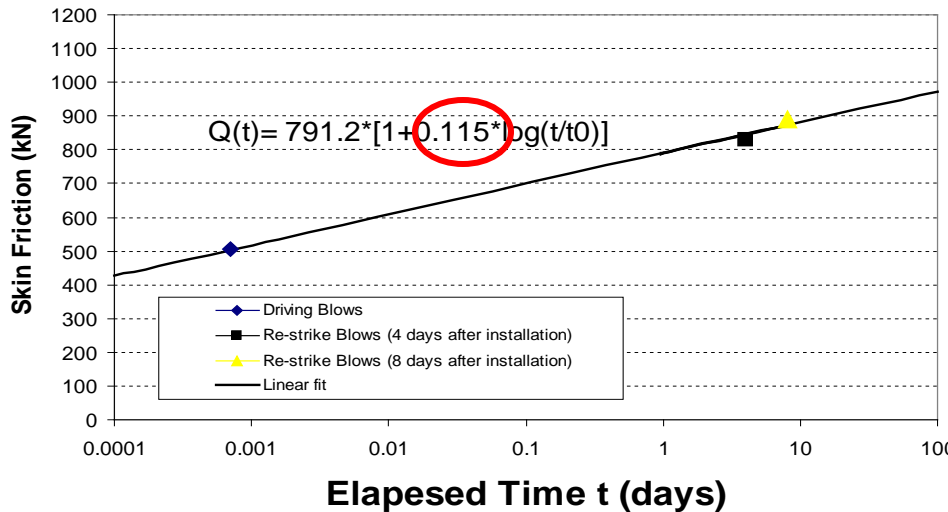

Skin Friction of Caminda Bay, Pile 1

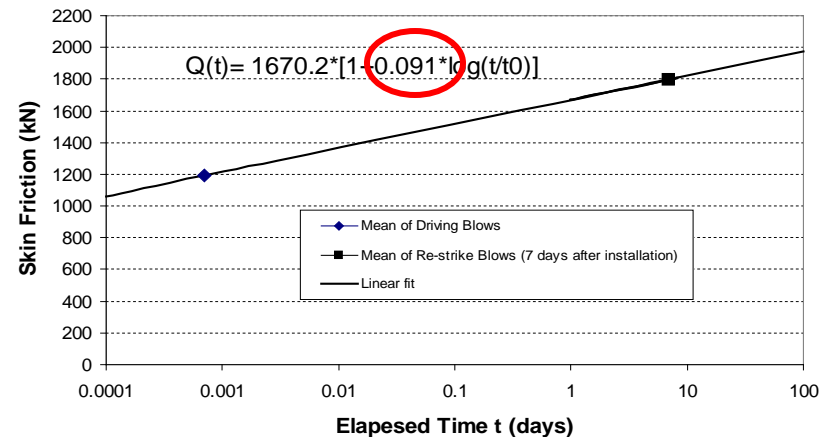

References:

Khiem T. Tran, Michael McVay, Rodrigo Herrera, and Peter Lai (2011), "A New Method for Estimating Driven Pile Static Skin Friction with Instrumentation at the Top and Bottom of the Pile", *Soil Dynamics and Earthquake Engineering*, Vol. 31 (9), pp 1285-1295.

Khiem T. Tran, Michael McVay, Rodrigo Herrera, and Peter Lai, "Estimating Static Tip Resistance of Driven Piles with Bottom Pile Instrumentation", *Canadian Journal of Geotechnical Engineering*, under review.

Khiem T. Tran, Michael McVay, Rodrigo Herrera, and Peter Lai, "Estimation of Nonlinear Static Skin Friction on Multiple Pile Segments Using Measured Hammer Impact Response at Top and Bottom of the Pile" *Computers and Geotechnics*, under review.

